



Cisco Content Engine 511 and 566 Hardware Installation Guide

Corporate Headquarters

Cisco Systems, Inc.
170 West Tasman Drive
San Jose, CA 95134-1706
USA
<http://www.cisco.com>
Tel: 408 526-4000
800 553-NETS (6387)
Fax: 408 526-4100

Text Part Number: OL-5756-01



THE SPECIFICATIONS AND INFORMATION REGARDING THE PRODUCTS IN THIS MANUAL ARE SUBJECT TO CHANGE WITHOUT NOTICE. ALL STATEMENTS, INFORMATION, AND RECOMMENDATIONS IN THIS MANUAL ARE BELIEVED TO BE ACCURATE BUT ARE PRESENTED WITHOUT WARRANTY OF ANY KIND, EXPRESS OR IMPLIED. USERS MUST TAKE FULL RESPONSIBILITY FOR THEIR APPLICATION OF ANY PRODUCTS.

THE SOFTWARE LICENSE AND LIMITED WARRANTY FOR THE ACCOMPANYING PRODUCT ARE SET FORTH IN THE INFORMATION PACKET THAT SHIPPED WITH THE PRODUCT AND ARE INCORPORATED HEREIN BY THIS REFERENCE. IF YOU ARE UNABLE TO LOCATE THE SOFTWARE LICENSE OR LIMITED WARRANTY, CONTACT YOUR CISCO REPRESENTATIVE FOR A COPY.

The following information is for FCC compliance of Class A devices: This equipment has been tested and found to comply with the limits for a Class A digital device, pursuant to part 15 of the FCC rules. These limits are designed to provide reasonable protection against harmful interference when the equipment is operated in a commercial environment. This equipment generates, uses, and can radiate radio-frequency energy and, if not installed and used in accordance with the instruction manual, may cause harmful interference to radio communications. Operation of this equipment in a residential area is likely to cause harmful interference, in which case users will be required to correct the interference at their own expense.

The following information is for FCC compliance of Class B devices: The equipment described in this manual generates and may radiate radio-frequency energy. If it is not installed in accordance with Cisco's installation instructions, it may cause interference with radio and television reception. This equipment has been tested and found to comply with the limits for a Class B digital device in accordance with the specifications in part 15 of the FCC rules. These specifications are designed to provide reasonable protection against such interference in a residential installation. However, there is no guarantee that interference will not occur in a particular installation.

Modifying the equipment without Cisco's written authorization may result in the equipment no longer complying with FCC requirements for Class A or Class B digital devices. In that event, your right to use the equipment may be limited by FCC regulations, and you may be required to correct any interference to radio or television communications at your own expense.

You can determine whether your equipment is causing interference by turning it off. If the interference stops, it was probably caused by the Cisco equipment or one of its peripheral devices. If the equipment causes interference to radio or television reception, try to correct the interference by using one or more of the following measures:

- Turn the television or radio antenna until the interference stops.
- Move the equipment to one side or the other of the television or radio.
- Move the equipment farther away from the television or radio.
- Plug the equipment into an outlet that is on a different circuit from the television or radio. (That is, make certain the equipment and the television or radio are on circuits controlled by different circuit breakers or fuses.)

Modifications to this product not authorized by Cisco Systems, Inc. could void the FCC approval and negate your authority to operate the product.

The Cisco implementation of TCP header compression is an adaptation of a program developed by the University of California, Berkeley (UCB) as part of UCB's public domain version of the UNIX operating system. All rights reserved. Copyright © 1981, Regents of the University of California.

NOTWITHSTANDING ANY OTHER WARRANTY HEREIN, ALL DOCUMENT FILES AND SOFTWARE OF THESE SUPPLIERS ARE PROVIDED "AS IS" WITH ALL FAULTS. CISCO AND THE ABOVE-NAMED SUPPLIERS DISCLAIM ALL WARRANTIES, EXPRESSED OR IMPLIED, INCLUDING, WITHOUT LIMITATION, THOSE OF MERCHANTABILITY, FITNESS FOR A PARTICULAR PURPOSE AND NONINFRINGEMENT OR ARISING FROM A COURSE OF DEALING, USAGE, OR TRADE PRACTICE.

IN NO EVENT SHALL CISCO OR ITS SUPPLIERS BE LIABLE FOR ANY INDIRECT, SPECIAL, CONSEQUENTIAL, OR INCIDENTAL DAMAGES, INCLUDING, WITHOUT LIMITATION, LOST PROFITS OR LOSS OR DAMAGE TO DATA ARISING OUT OF THE USE OR INABILITY TO USE THIS MANUAL, EVEN IF CISCO OR ITS SUPPLIERS HAVE BEEN ADVISED OF THE POSSIBILITY OF SUCH DAMAGES.

CCSP, the Cisco Square Bridge logo, Cisco Unity, Follow Me Browsing, FormShare, and StackWise are trademarks of Cisco Systems, Inc.; Changing the Way We Work, Live, Play, and Learn, and iQuick Study are service marks of Cisco Systems, Inc.; and Aironet, ASIST, BPX, Catalyst, CCDA, CCDP, CCIE, CCIP, CCNA, CCNP, Cisco, the Cisco Certified Internetwork Expert logo, Cisco IOS, Cisco Press, Cisco Systems, Cisco Systems Capital, the Cisco Systems logo, Empowering the Internet Generation, Enterprise/Solver, EtherChannel, EtherFast, EtherSwitch, Fast Step, GigaDrive, GigaStack, HomeLink, Internet Quotient, IOS, IP/TV, iQ Expertise, the iQ logo, iQ Net Readiness Scorecard, LightStream, Linksys, MeetingPlace, MGX, the Networkers logo, Networking Academy, Network Registrar, *Packet*, PIX, Post-Routing, Pre-Routing, ProConnect, RateMUX, Registrar, ScriptShare, SlideCast, SMARTnet, StrataView Plus, SwitchProbe, TeleRouter, The Fastest Way to Increase Your Internet Quotient, TransPath, and VCO are registered trademarks of Cisco Systems, Inc. and/or its affiliates in the United States and certain other countries.

All other trademarks mentioned in this document or Website are the property of their respective owners. The use of the word partner does not imply a partnership relationship between Cisco and any other company. (0406R)

Cisco Content Engine 511 and 566 Hardware Installation Guide
Copyright © 2004 Cisco Systems, Inc. All rights reserved.



Preface ix

Document Objectives	ix
Audience	x
Document Organization	x
Document Conventions	xi
Obtaining Documentation	xxi
Cisco.com	xxi
Ordering Documentation	xxi
Documentation Feedback	xxii
Obtaining Technical Assistance	xxii
Cisco Technical Support Website	xxii
Submitting a Service Request	xxiii
Definitions of Service Request Severity	xxiv
Obtaining Additional Publications and Information	xxiv

CHAPTER 1

Introducing the Content Engine 1-1

Introduction	1-1
Content Engine 511	1-4
Content Engine 566	1-4
Functional Description	1-4
Content Delivery Network Component	1-5
Content Caching Device	1-5
Hardware Features	1-6
Front Panel Control Buttons	1-7

- LED Indicators 1-8
- Input/Output Ports and Connectors 1-11
 - Ethernet Port 1-13
 - Serial Port 1-13
 - SCSI Port 1-14
 - Fibre Channel Port 1-14
 - Video Port 1-15
- Specifications 1-17
- Regulatory Compliance 1-20
- Class A Warning Statements 1-22
 - VCCI Class A Warning for Japan 1-22
 - Class A Notice for Taiwan and Other Traditional Chinese Markets 1-22
 - Class A Warning for Hungary 1-23

CHAPTER 2

Preparing to Install the Content Engine 2-1

- Safety Warnings 2-1
- Safety Guidelines 2-4
 - General Precautions 2-4
 - Protecting Against Electrostatic Discharge 2-6
 - Rack Installation Safety Guidelines 2-6

CHAPTER 3

Installing the Content Engine 3-1

- Tools and Parts Required 3-1
- Installing a CE-511 or CE-566 Unit 3-2
 - Installing the Chassis in a 2-Post Rack 3-3
 - Installing the Chassis in a 4-Post Rack 3-4
 - Installing the Chassis on a Tabletop 3-11
- Connecting Cables 3-12
- Connecting Power and Booting the System 3-13

- Checking the LEDs 3-14
- Removing or Replacing a Content Engine 3-14

CHAPTER 4**Installing Hardware Options 4-1**

- Removing the Cover and Bezel 4-1
- Installing Adapters 4-3
 - Installing an MPEG Decoder Adapter 4-5
 - Preparing and Installing a Fibre Channel Adapter 4-8
 - Preparing to Install the Adapter 4-9
 - Installing the Fibre Channel Adapter 4-10
 - Troubleshooting the Fibre Channel Adapter Installation 4-10
- Working with Hard Disk Drives 4-12
 - Installing a Hard Disk Drive in the CE-511 4-12
 - Installing a Hard Disk Drive in the CE-566 4-14
 - Assigning SCSI IDs 4-16
- Completing the Installation 4-16
 - Installing the Content Engine Cover and Bezel 4-17

CHAPTER 5**Troubleshooting the System Hardware 5-1**

- Checking the Basics 5-1
- Checking Connections and Switches 5-2

CHAPTER 6**Maintaining the Content Engine 6-1**

- Maintaining Your Site Environment 6-1
 - Temperature 6-2
 - Humidity 6-3
 - Altitude 6-3
 - Dust and Particles 6-3
 - Corrosion 6-4

- Electrostatic Discharge 6-4
- Electromagnetic and Radio Frequency Interference 6-5
- Magnetism 6-5
- Power Source Interruptions 6-6
- Using Power Protection Devices 6-7
 - Surge Protectors 6-7
 - Line Conditioners 6-7
 - Uninterruptible Power Supplies 6-7

INDEX



Preface

This preface describes who should read the *Cisco Content Engine 511 and 566 Hardware Installation Guide*, how it is organized, and its document conventions.

This preface contains the following sections:

- [Document Objectives, page ix](#)
- [Audience, page x](#)
- [Document Organization, page x](#)
- [Document Conventions, page xi](#)
- [Obtaining Documentation, page xxi](#)
- [Obtaining Documentation, page xxi](#)
- [Documentation Feedback, page xxii](#)
- [Obtaining Technical Assistance, page xxii](#)
- [Obtaining Additional Publications and Information, page xxiv](#)

Document Objectives

This installation guide explains how to prepare your site for installation, how to install a Content Engine in an equipment rack, and how to maintain and troubleshoot the system hardware. After completing the hardware installation procedures covered in this guide, you will then use the appropriate companion publications to configure your system. (See the [“Obtaining Documentation” section on page xxi.](#))

Audience

To use this hardware publication, you should be familiar with internetworking equipment and cabling, and have a basic knowledge of electronic circuitry and wiring practices.

To complete the installation, including the software configuration for the Content Engine and for the router with which it works in conjunction, you should be familiar with basic networking principles and router configuration, especially web page protocols.



Warning

Only trained and qualified personnel should be allowed to install, replace, or service this equipment. Statement 1030

Document Organization

This guide includes the following chapters:

Chapter	Title	Description
Chapter 1	Introducing the Content Engine	Describes the physical properties and provides a functional overview of the Cisco Content Engine 511 and 566.
Chapter 2	Preparing to Install the Content Engine	Describes safety considerations and gives an overview of the installation and procedures you should perform <i>before</i> the actual installation.
Chapter 3	Installing the Content Engine	Describes installing the hardware and connecting the external network interface cables.

Chapter	Title	Description
Chapter 4	Installing Hardware Options	Describes how to remove and replace the MPEG A/V decoder adapter, the Fibre Channel adapter, and hard disk drives.
Chapter 5	Troubleshooting the System Hardware	Describes troubleshooting procedures for the hardware installation.
Chapter 6	Maintaining the Content Engine	Contains the procedures for keeping your Content Engine in good condition.

Document Conventions

Command descriptions use the following conventions:

Convention	Description
boldface font	Commands and keywords are in boldface .
<i>italic</i> font	Variables for which you supply values are in <i>italics</i> .
[]	Elements in square brackets are optional.
{x y z}	Alternative keywords are grouped in braces and separated by vertical bars.
[x y z]	Optional alternative keywords are grouped in brackets and separated by vertical bars.
string	A nonquoted set of characters. Do not use quotation marks around the string, or the string will include the quotation marks.

Screen examples use the following conventions:

Convention	Description
screen font	Terminal sessions and information the system displays are in <i>screen font</i> .
boldface screen font	Information you must enter is in boldface screen font .
<i>italic screen font</i>	Variables for which you supply values are in <i>italic screen font</i> .
^	The symbol ^ represents the key labeled Control—for example, the key combination ^D in a screen display means hold down the Control key while you press the D key.
< >	Nonprinting characters, such as passwords, are in angle brackets.
[]	Default responses to system prompts are in square brackets.
!, #	An exclamation point (!) or a pound sign (#) at the beginning of a line of code indicates a comment line.

Notes, cautionary statements, and safety warnings use these conventions:



Note

Means *reader take note*. Notes contain helpful suggestions or references to materials not contained in this manual.



Caution

Means *reader be careful*. You are capable of doing something that might result in equipment damage or loss of data.

**Warning****IMPORTANT SAFETY INSTRUCTIONS**

This warning symbol means danger. You are in a situation that could cause bodily injury. Before you work on any equipment, be aware of the hazards involved with electrical circuitry and be familiar with standard practices for preventing accidents. Use the statement number provided at the end of each warning to locate its translation in the translated safety warnings that accompanied this device. Statement 1071

SAVE THESE INSTRUCTIONS**Waarschuwing****BELANGRIJKE VEILIGHEIDSINSTRUCTIES**

Dit waarschuwingssymbool betekent gevaar. U verkeert in een situatie die lichamelijk letsel kan veroorzaken. Voordat u aan enige apparatuur gaat werken, dient u zich bewust te zijn van de bij elektrische schakelingen betrokken risico's en dient u op de hoogte te zijn van de standaard praktijken om ongelukken te voorkomen. Gebruik het nummer van de verklaring onderaan de waarschuwing als u een vertaling van de waarschuwing die bij het apparaat wordt geleverd, wilt raadplegen.

BEWAAR DEZE INSTRUCTIES**Varoitus****TÄRKEITÄ TURVALLISUUSOHJEITA**

Tämä varoitusmerkki merkitsee vaaraa. Tilanne voi aiheuttaa ruumiillisia vammoja. Ennen kuin käsittelet laitteistoa, huomioi sähköpiirien käsittelemiseen liittyvät riskit ja tutustu onnettomuuksien yleisiin ehkäisytapoihin. Turvallisuusvaroitusten käännökset löytyvät laitteen mukana toimitettujen käännettyjen turvallisuusvaroitusten joukosta varoitusten lopussa näkyvien lausuntonumeroiden avulla.

SÄILYTÄ NÄMÄ OHJEET

Attention IMPORTANTES INFORMATIONS DE SÉCURITÉ

Ce symbole d'avertissement indique un danger. Vous vous trouvez dans une situation pouvant entraîner des blessures ou des dommages corporels. Avant de travailler sur un équipement, soyez conscient des dangers liés aux circuits électriques et familiarisez-vous avec les procédures couramment utilisées pour éviter les accidents. Pour prendre connaissance des traductions des avertissements figurant dans les consignes de sécurité traduites qui accompagnent cet appareil, référez-vous au numéro de l'instruction situé à la fin de chaque avertissement.

CONSERVEZ CES INFORMATIONS**Warnung WICHTIGE SICHERHEITSHINWEISE**

Dieses Warnsymbol bedeutet Gefahr. Sie befinden sich in einer Situation, die zu Verletzungen führen kann. Machen Sie sich vor der Arbeit mit Geräten mit den Gefahren elektrischer Schaltungen und den üblichen Verfahren zur Vorbeugung vor Unfällen vertraut. Suchen Sie mit der am Ende jeder Warnung angegebenen Anweisungsnummer nach der jeweiligen Übersetzung in den übersetzten Sicherheitshinweisen, die zusammen mit diesem Gerät ausgeliefert wurden.

BEWAHREN SIE DIESE HINWEISE GUT AUF.**Avvertenza IMPORTANTI ISTRUZIONI SULLA SICUREZZA**

Questo simbolo di avvertenza indica un pericolo. La situazione potrebbe causare infortuni alle persone. Prima di intervenire su qualsiasi apparecchiatura, occorre essere al corrente dei pericoli relativi ai circuiti elettrici e conoscere le procedure standard per la prevenzione di incidenti. Utilizzare il numero di istruzione presente alla fine di ciascuna avvertenza per individuare le traduzioni delle avvertenze riportate in questo documento.

CONSERVARE QUESTE ISTRUZIONI

Advarsel VIKTIGE SIKKERHETSINSTRUKSJONER

Dette advarselssymbolet betyr fare. Du er i en situasjon som kan føre til skade på person. Før du begynner å arbeide med noe av utstyret, må du være oppmerksom på farene forbundet med elektriske kretser, og kjenne til standardprosedyrer for å forhindre ulykker. Bruk nummeret i slutten av hver advarsel for å finne oversettelsen i de oversatte sikkerhetsadvarslene som fulgte med denne enheten.

TA VARE PÅ DISSE INSTRUKSJONENE**Aviso INSTRUÇÕES IMPORTANTES DE SEGURANÇA**

Este símbolo de aviso significa perigo. Você está em uma situação que poderá ser causadora de lesões corporais. Antes de iniciar a utilização de qualquer equipamento, tenha conhecimento dos perigos envolvidos no manuseio de circuitos elétricos e familiarize-se com as práticas habituais de prevenção de acidentes. Utilize o número da instrução fornecido ao final de cada aviso para localizar sua tradução nos avisos de segurança traduzidos que acompanham este dispositivo.

GUARDE ESTAS INSTRUÇÕES**¡Advertencia! INSTRUCCIONES IMPORTANTES DE SEGURIDAD**

Este símbolo de aviso indica peligro. Existe riesgo para su integridad física. Antes de manipular cualquier equipo, considere los riesgos de la corriente eléctrica y familiarícese con los procedimientos estándar de prevención de accidentes. Al final de cada advertencia encontrará el número que le ayudará a encontrar el texto traducido en el apartado de traducciones que acompaña a este dispositivo.

GUARDE ESTAS INSTRUCCIONES

Varning! VIKTIGA SÄKERHETSANVISNINGAR

Denna varningssignal signalerar fara. Du befinner dig i en situation som kan leda till personskada. Innan du utför arbete på någon utrustning måste du vara medveten om farorna med elkretsar och känna till vanliga förfaranden för att förebygga olyckor. Använd det nummer som finns i slutet av varje varning för att hitta dess översättning i de översatta säkerhetsvarningar som medföljer denna anordning.

SPARA DESSA ANVISNINGAR**Figyelem FONTOS BIZTONSÁGI ELOÍRÁSOK**

Ez a figyelmeztető jel veszélyre utal. Sérülésveszélyt rejtő helyzetben van. Mielőtt bármely berendezésen munkát végezte, legyen figyelemmel az elektromos áramkörök okozta kockázatokra, és ismerkedjen meg a szokásos balesetvédelmi eljárásokkal. A kiadványban szereplő figyelmeztetések fordítása a készülékhez mellékelt biztonsági figyelmeztetések között található; a fordítás az egyes figyelmeztetések végén látható szám alapján kereshető meg.

ORIZZE MEG EZEKET AZ UTASÍTÁSOKAT!**Предупреждение ВАЖНЫЕ ИНСТРУКЦИИ ПО СОБЛЮДЕНИЮ ТЕХНИКИ БЕЗОПАСНОСТИ**

Этот символ предупреждения обозначает опасность. То есть имеет место ситуация, в которой следует опасаться телесных повреждений. Перед эксплуатацией оборудования выясните, каким опасностям может подвергаться пользователь при использовании электрических цепей, и ознакомьтесь с правилами техники безопасности для предотвращения возможных несчастных случаев. Воспользуйтесь номером заявления, приведенным в конце каждого предупреждения, чтобы найти его переведенный вариант в переводе предупреждений по безопасности, прилагаемом к данному устройству.

СОХРАНИТЕ ЭТИ ИНСТРУКЦИИ

警告 重要的安全性说明

此警告符号代表危险。您正处于可能受到严重伤害的工作环境中。在您使用设备开始工作之前，必须充分意识到触电的危险，并熟练掌握防止事故发生的标准工作程序。请根据每项警告结尾提供的声明号码来找到此设备的安全性警告说明的翻译文本。

请保存这些安全性说明

警告 安全上の重要な注意事項

「危険」の意味です。人身事故を予防するための注意事項が記述されています。装置の取り扱い作業を行うときは、電気回路の危険性に注意し、一般的な事故防止策に留意してください。警告の各国語版は、各注意事項の番号を基に、装置に付属の「Translated Safety Warnings」を参照してください。

これらの注意事項を保管しておいてください。

주의 重要 안전 지침

이 경고 기호는 위험을 나타냅니다. 작업자가 신체 부상을 일으킬 수 있는 위험한 환경에 있습니다. 장비에 작업을 수행하기 전에 전기 회로와 관련된 위험을 숙지하고 표준 작업 관례를 숙지하여 사고를 방지하십시오. 각 경고의 마지막 부분에 있는 경고문 번호를 참조하여 이 장치와 함께 제공되는 번역된 안전 경고문에서 해당 번역문을 찾으십시오.

이 지시 사항을 보관하십시오.

Aviso **INSTRUÇÕES IMPORTANTES DE SEGURANÇA**

Este símbolo de aviso significa perigo. Você se encontra em uma situação em que há risco de lesões corporais. Antes de trabalhar com qualquer equipamento, esteja ciente dos riscos que envolvem os circuitos elétricos e familiarize-se com as práticas padrão de prevenção de acidentes. Use o número da declaração fornecido ao final de cada aviso para localizar sua tradução nos avisos de segurança traduzidos que acompanham o dispositivo.

GUARDE ESTAS INSTRUÇÕES

Advarsel VIGTIGE SIKKERHEDSANVISNINGER

Dette advarselssymbol betyder fare. Du befinder dig i en situation med risiko for legemesbeskadigelse. Før du begynder arbejde på udstyr, skal du være opmærksom på de involverede risici, der er ved elektriske kredsløb, og du skal sætte dig ind i standardprocedurer til undgåelse af ulykker. Brug erklæringsnummeret efter hver advarsel for at finde oversættelsen i de oversatte advarsler, der fulgte med denne enhed.

GEM DISSE ANVISNINGER

تحذير

إرشادات الأمان الهامة

يوضح رمز التحذير هذا وجود خطر. وهذا يعني أنك متواجد في مكان قد ينتج عنه التعرض لإصابات. قبل بدء العمل، احذر مخاطر التعرض للصدمات الكهربائية وكن على علم بالإجراءات القياسية للحيلولة دون وقوع أي حوادث. استخدم رقم البيان الموجود في آخر كل تحذير لتحديد مكان ترجمته داخل تحذيرات الأمان المترجمة التي تأتي مع الجهاز. قم بحفظ هذه الإرشادات

Upozorenje VAŽNE SIGURNOSNE NAPOMENE

Ovaj simbol upozorenja predstavlja opasnost. Nalazite se u situaciji koja može prouzročiti tjelesne ozljede. Prije rada s bilo kojim uređajem, morate razumjeti opasnosti vezane uz električne sklopove, te biti upoznati sa standardnim načinima izbjegavanja nesreća. U prevedenim sigurnosnim upozorenjima, priloženima uz uređaj, možete prema broju koji se nalazi uz pojedino upozorenje pronaći i njegov prijevod.

SAČUVAJTE OVE UPUTE

Upozornění **DŮLEŽITÉ BEZPEČNOSTNÍ POKYNY**

Tento upozorňující symbol označuje nebezpečí. Jste v situaci, která by mohla způsobit nebezpečí úrazu. Před prací na jakémkoliv vybavení si uvědomte nebezpečí související s elektrickými obvody a seznamte se se standardními opatřeními pro předcházení úrazům. Podle čísla na konci každého upozornění vyhledejte jeho překlad v přeložených bezpečnostních upozorněních, která jsou přiložena k zařízení.

USCHOVEJTE TYTO POKYNY

Προειδοποίηση **ΣΗΜΑΝΤΙΚΕΣ ΟΔΗΓΙΕΣ ΑΣΦΑΛΕΙΑΣ**

Αυτό το προειδοποιητικό σύμβολο σημαίνει κίνδυνο. Βρίσκεστε σε κατάσταση που μπορεί να προκαλέσει τραυματισμό. Πριν εργαστείτε σε οποιοδήποτε εξοπλισμό, να έχετε υπόψη σας τους κινδύνους που σχετίζονται με τα ηλεκτρικά κυκλώματα και να έχετε εξοικειωθεί με τις συνήθεις πρακτικές για την αποφυγή ατυχημάτων. Χρησιμοποιήστε τον αριθμό δήλωσης που παρέχεται στο τέλος κάθε προειδοποίησης, για να εντοπίσετε τη μετάφρασή της στις μεταφρασμένες προειδοποιήσεις ασφαλείας που συνοδεύουν τη συσκευή.

ΦΥΛΑΞΤΕ ΑΥΤΕΣ ΤΙΣ ΟΔΗΓΙΕΣ

אזהרה

הוראות בטיחות חשובות

סימן אזהרה זה מסמל סכנה. אתה נמצא במצב בעלול לגרום לפציעה. לפני שתעבוד עם ציוד כלשהו, עליך להיות מודע לסכנות הכרוכות במעגלים חשמליים ולהכיר את הנהלים המקובלים למניעת תאונות. השתמש במספר ההוראה המסופק בסופה של כל אזהרה כדי לאתר את התרגום באזהרות הבטיחות המתורגמות שמצורפות להתקן.

שמור הוראות אלה

Opomena **ВАЖНИ БЕЗБЕДНОСНИ НАПАТСТВИЈА**
Симболот за предупредување значи опасност. Се наоѓате во ситуација што може да предизвика телесни повреди. Пред да работите со опремата, бидете свесни за ризикот што постои кај електричните кола и треба да ги познавате стандардните постапки за спречување на несреќни случаи. Искористете го бројот на изјавата што се наоѓа на крајот на секое предупредување за да го најдете неговиот период во преведените безбедносни предупредувања што се испорачани со уредот.
ЧУВАЈТЕ ГИ ОВИЕ НАПАТСТВИЈА

Ostrzeżenie **WAŻNE INSTRUKCJE DOTYCZĄCE BEZPIECZEŃSTWA**
Ten symbol ostrzeżenia oznacza niebezpieczeństwo. Zachodzi sytuacja, która może powodować obrażenia ciała. Przed przystąpieniem do prac przy urządzeniach należy zapoznać się z zagrożeniami związanymi z układami elektrycznymi oraz ze standardowymi środkami zapobiegania wypadkom. Na końcu każdego ostrzeżenia podano numer, na podstawie którego można odszukać tłumaczenie tego ostrzeżenia w dołączonym do urządzenia dokumencie z tłumaczeniami ostrzeżeń.

NINIEJSZE INSTRUKCJE NALEŻY ZACHOWAĆ

Upozornenie **DŮLEŽITÉ BEZPEČNOSTNÉ POKYNY**
Tento varovný symbol označuje nebezpečenstvo. Nachádzate sa v situácii s nebezpečenstvom úrazu. Pred prácou na akomkoľvek vybavení si uvedomte nebezpečenstvo súvisiace s elektrickými obvodmi a oboznámte sa so štandardnými opatreniami na predchádzanie úrazom. Podľa čísla na konci každého upozornenia vyhľadajte jeho preklad v preložených bezpečnostných upozorneniach, ktoré sú priložené k zariadeniu.

USCHOVAJTE SI TENTO NÁVOD

Obtaining Documentation

Cisco documentation and additional literature are available on Cisco.com. Cisco also provides several ways to obtain technical assistance and other technical resources. These sections explain how to obtain technical information from Cisco Systems.

Cisco.com

You can access the most current Cisco documentation at this URL:

<http://www.cisco.com/univercd/home/home.htm>

You can access the Cisco website at this URL:

<http://www.cisco.com>

You can access international Cisco websites at this URL:

http://www.cisco.com/public/countries_languages.shtml

Ordering Documentation

You can find instructions for ordering documentation at this URL:

http://www.cisco.com/univercd/cc/td/doc/es_inpk/pdi.htm

You can order Cisco documentation in these ways:

- Registered Cisco.com users (Cisco direct customers) can order Cisco product documentation from the Ordering tool:

<http://www.cisco.com/en/US/partner/ordering/index.shtml>

- Nonregistered Cisco.com users can order documentation through a local account representative by calling Cisco Systems Corporate Headquarters (California, USA) at 408 526-7208 or, elsewhere in North America, by calling 1 800 553-NETS (6387).

Documentation Feedback

You can send comments about technical documentation to bug-doc@cisco.com.

You can submit comments by using the response card (if present) behind the front cover of your document or by writing to the following address:

Cisco Systems
Attn: Customer Document Ordering
170 West Tasman Drive
San Jose, CA 95134-9883

We appreciate your comments.

Obtaining Technical Assistance

For all customers, partners, resellers, and distributors who hold valid Cisco service contracts, Cisco Technical Support provides 24-hour-a-day, award-winning technical assistance. The Cisco Technical Support Website on Cisco.com features extensive online support resources. In addition, Cisco Technical Assistance Center (TAC) engineers provide telephone support. If you do not hold a valid Cisco service contract, contact your reseller.

Cisco Technical Support Website

The Cisco Technical Support Website provides online documents and tools for troubleshooting and resolving technical issues with Cisco products and technologies. The website is available 24 hours a day, 365 days a year, at this URL:

<http://www.cisco.com/techsupport>

Access to all tools on the Cisco Technical Support Website requires a Cisco.com user ID and password. If you have a valid service contract but do not have a user ID or password, you can register at this URL:

<http://tools.cisco.com/RPF/register/register.do>

**Note**

Use the Cisco Product Identification (CPI) tool to locate your product serial number before submitting a web or phone request for service. You can access the CPI tool from the Cisco Technical Support Website by clicking the **Tools & Resources** link under Documentation & Tools. Choose **Cisco Product Identification Tool** from the Alphabetical Index drop-down list, or click the **Cisco Product Identification Tool** link under Alerts & RMAs. The CPI tool offers three search options: by product ID or model name; by tree view; or for certain products, by copying and pasting **show** command output. Search results show an illustration of your product with the serial number label location highlighted. Locate the serial number label on your product and record the information before placing a service call.

Submitting a Service Request

Using the online TAC Service Request Tool is the fastest way to open S3 and S4 service requests. (S3 and S4 service requests are those in which your network is minimally impaired or for which you require product information.) After you describe your situation, the TAC Service Request Tool provides recommended solutions. If your issue is not resolved using the recommended resources, your service request is assigned to a Cisco TAC engineer. The TAC Service Request Tool is located at this URL:

<http://www.cisco.com/techsupport/servicerequest>

For S1 or S2 service requests or if you do not have Internet access, contact the Cisco TAC by telephone. (S1 or S2 service requests are those in which your production network is down or severely degraded.) Cisco TAC engineers are assigned immediately to S1 and S2 service requests to help keep your business operations running smoothly.

To open a service request by telephone, use one of the following numbers:

Asia-Pacific: +61 2 8446 7411 (Australia: 1 800 805 227)

EMEA: +32 2 704 55 55

USA: 1 800 553-2447

For a complete list of Cisco TAC contacts, go to this URL:

<http://www.cisco.com/techsupport/contacts>

Definitions of Service Request Severity

To ensure that all service requests are reported in a standard format, Cisco has established severity definitions.

Severity 1 (S1)—Your network is “down,” or there is a critical impact to your business operations. You and Cisco will commit all necessary resources around the clock to resolve the situation.

Severity 2 (S2)—Operation of an existing network is severely degraded, or significant aspects of your business operation are negatively affected by inadequate performance of Cisco products. You and Cisco will commit full-time resources during normal business hours to resolve the situation.

Severity 3 (S3)—Operational performance of your network is impaired, but most business operations remain functional. You and Cisco will commit resources during normal business hours to restore service to satisfactory levels.

Severity 4 (S4)—You require information or assistance with Cisco product capabilities, installation, or configuration. There is little or no effect on your business operations.

Obtaining Additional Publications and Information

Information about Cisco products, technologies, and network solutions is available from various online and printed sources.

- Cisco Marketplace provides a variety of Cisco books, reference guides, and logo merchandise. Visit Cisco Marketplace, the company store, at this URL:
<http://www.cisco.com/go/marketplace/>
- The Cisco *Product Catalog* describes the networking products offered by Cisco Systems, as well as ordering and customer support services. Access the Cisco Product Catalog at this URL:
<http://cisco.com/univercd/cc/td/doc/pcat/>
- *Cisco Press* publishes a wide range of general networking, training and certification titles. Both new and experienced users will benefit from these publications. For current Cisco Press titles and other information, go to Cisco Press at this URL:
<http://www.ciscopress.com>

- *Packet* magazine is the Cisco Systems technical user magazine for maximizing Internet and networking investments. Each quarter, Packet delivers coverage of the latest industry trends, technology breakthroughs, and Cisco products and solutions, as well as network deployment and troubleshooting tips, configuration examples, customer case studies, certification and training information, and links to scores of in-depth online resources. You can access Packet magazine at this URL:

<http://www.cisco.com/packet>

- *iQ Magazine* is the quarterly publication from Cisco Systems designed to help growing companies learn how they can use technology to increase revenue, streamline their business, and expand services. The publication identifies the challenges facing these companies and the technologies to help solve them, using real-world case studies and business strategies to help readers make sound technology investment decisions. You can access iQ Magazine at this URL:

<http://www.cisco.com/go/iqmagazine>

- *Internet Protocol Journal* is a quarterly journal published by Cisco Systems for engineering professionals involved in designing, developing, and operating public and private internets and intranets. You can access the Internet Protocol Journal at this URL:

<http://www.cisco.com/ipj>

- World-class networking training is available from Cisco. You can view current offerings at this URL:

<http://www.cisco.com/en/US/learning/index.html>



Introducing the Content Engine

This chapter provides a basic functional overview of the Cisco Content Engine 511 and 566 (CE-511 and CE-566), and describes the Content Engine hardware, major components, and front and back panel indicators and controls.

This chapter contains the following sections:

- [Introduction, page 1-1](#)
- [Functional Description, page 1-4](#)
- [Hardware Features, page 1-6](#)
- [Specifications, page 1-17](#)
- [Regulatory Compliance, page 1-20](#)
- [Class A Warning Statements, page 1-22](#)

Introduction

The CE-511 and CE-566 (see [Figure 1-1](#)) are Internet content delivery devices that offer content caching, hosting, content replication, video streaming, and other content-based services. The Content Engine is positioned on the WAN edge between your small business site or enterprise network and the Internet.

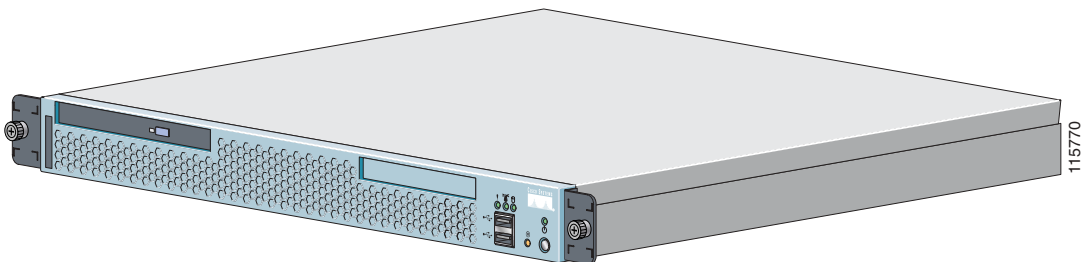
Figure 1-1 CE-511 and CE-566—Front View

This guide describes the Content Engine models listed below.

Model	Product Number
Content Engine 511	CE-511-K9
Content Engine 566	CE-566A-144GB-K9

The CE-511 and CE-566 are configured for AC-input power and have a single AC-input power supply.

The Content Engine comes with an integrated dual-port Ethernet controller. This controller provides an interface for connecting to 10-Mbps, 100-Mbps, or 1000-Mbps networks.

Content Engines have two 10BASE-T/100BASE-TX/1000BASE-TX Ethernet ports with RJ-45 receptacles. Both Ethernet ports support autodetect speed mode and full-duplex operation, which enable simultaneous transmission and reception of data on the Ethernet LAN.

In addition, the CE-566 is configured with one Ultra320 low-voltage differential (LVD) small computer system interface (SCSI) connector for attaching the Cisco Storage Array. The SCSI adapter is installed in Peripheral Component Interconnect-Extended (PCI-X) slot 2 on the back panel. (See [Figure 1-2](#).)

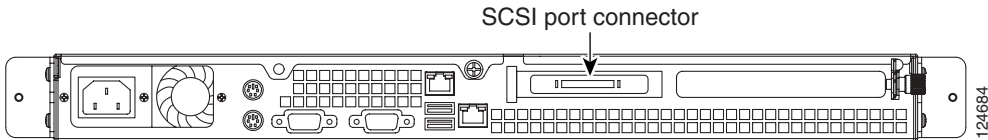
Figure 1-2 CE-566 Back Panel with SCSI Port Connector

CE-511 and 566 Models can be configured with either a Fibre Channel adapter or an MPEG A/V decoder adapter. These adapters are user-replaceable and are installed in PCI-X slot 1 on the back panel.

[Figure 1-3](#) shows the CE-511 and CE-566 back panel with a Fibre Channel adapter installed in slot PCI 1, and [Figure 1-4](#) shows the Content Engine back panel with an MPEG A/V decoder adapter installed in slot PCI 1.

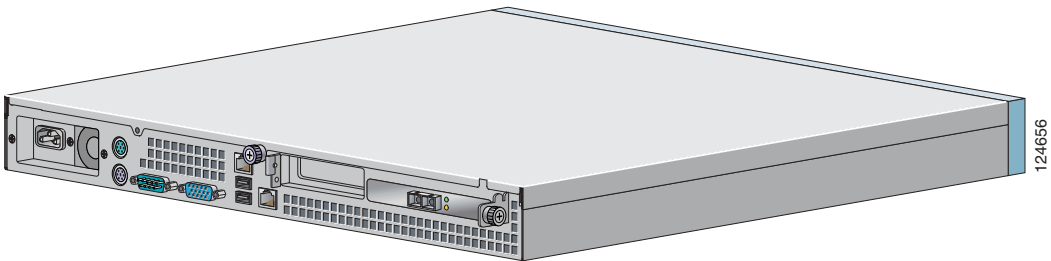
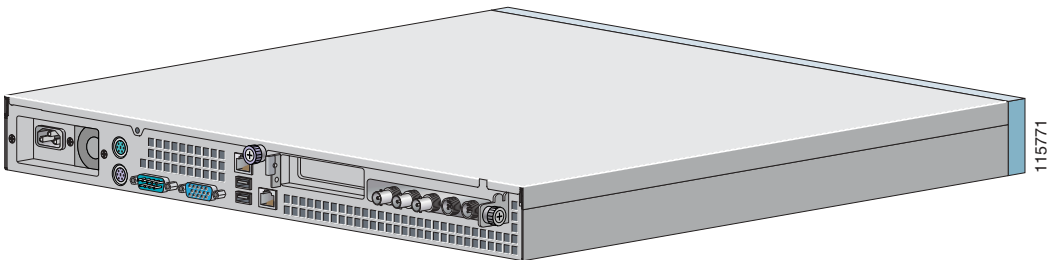
Figure 1-3 CE-511 and CE-566 Back Panel with Fibre Channel Adapter**Figure 1-4 CE-511 and CE-566 Back Panel with MPEG A/V Decoder Adapter**

Content Engine 511

The Content Engine 511 (CE-511) is a base-end Content Engine that services small- to medium-size enterprise networks.

[Table 1-1](#) lists memory specifications for the CE-511.

Table 1-1 *CE-511 Memory Specifications*

Specification	Description
Memory	512 MB DRAM
Hard disk drives	1 80-GB SATA ¹ hard disk drive (CE-511-DISK-80GB) Note The Content Engine 511 can be upgraded to a maximum of 2 hard disk drives.

1. SATA = Serial Advanced Technology Attachment

Content Engine 566

The Content Engine 566 (CE-566) is a mid-range Content Engine that services medium- to large-size enterprise networks.

[Table 1-2](#) lists memory specifications for the CE-566.

Table 1-2 *CE-566 Memory Specifications*

Specification	Description
Memory	1 GB DRAM
Hard disk drives	2 72-GB SCSI hard disk drives (CE-566-DISK-72GB)

Functional Description

The Content Engine operates either as a component of a Cisco Application and Content Networking System (ACNS) or as a standalone content-caching device and is generally positioned on the WAN edge between your enterprise and the Internet.

The CE-566 supports device mode configuration and can be configured through ACNS 5.x software to operate as a Content Engine, a Content Router, a Content Distribution Manager, or an IP/TV Program Manager. The CE-511, however, does not support device mode configuration.

Content Delivery Network Component

Cisco Content Engines with Cisco ACNS software installed are the content delivery components of a larger Cisco ACNS network solution, which includes content routing and content distribution and management. Content Engines with Cisco ACNS 5.x software are deployed in conjunction with a Content Distribution Manager to create a centrally managed ACNS network.

The ACNS solution offers accelerated content delivery, hosting, content replication, video streaming, and other content-based services. The ACNS solution addresses the need to distribute and receive high-bandwidth, media-rich content across the Internet or an intranet without performance losses or content delivery delays.

Content Caching Device

Cisco Content Engines with Cisco ACNS software installed accelerate content delivery and optimize bandwidth usage by transparently caching frequently accessed content and fulfilling content requests locally rather than traversing the Internet or intranet to a distant server farm each time a request is made. The Content Engine works in tandem with a router to handle web traffic, including user requests to view pages and graphics (objects) on World Wide Web servers—whether internal or external to your network.

To deploy Cisco Content Engines with Cisco ACNS software within your existing network, your network must support Cisco IOS software and the Web Cache Communication Protocol (WCCP). WCCP transparently redirects HTTP requests to a Content Engine, and the Content Engine responds to those requests.

For example, when a user requests an object from a web server, the router first sends the request to a Content Engine. If the Content Engine has a copy of the requested object in storage, the Content Engine sends the user the object.

Otherwise, the Content Engine simultaneously obtains the requested objects from the web server, stores a copy of the objects (caches them), and forwards the objects on to the user.

You can also configure your Content Engine as a proxy server that acts as a network gateway device, which is optimized to retrieve content on behalf of web clients. Direct proxy routing is known as nontransparent caching because the web clients and media players in the network are configured to explicitly point to the Content Engine that is acting as the proxy server.

**Note**

Unlike transparent caching, nontransparent caching is possible even if your network does not support Cisco IOS software and the WCCP.

In nontransparent caching cases, the Content Engine sends the content to the web client from its local storage if the requested content is already available at that location (cache hit). If the requested content is not already stored in the Content Engine's local cache (cache miss), the Content Engine retrieves the requested content from the origin server, stores a local copy of the content if the content is cacheable, and sends the requested content to the web client. When the Content Engine receives subsequent requests for the same content, it sends the content from its local storage.

By caching web objects, the Content Engine can speed the completion of user requests when more than one user wants to access the same objects. Caching in this manner also reduces the amount of traffic between your network and the Internet, potentially improving your overall network performance and optimizing your bandwidth usage.

Hardware Features

This section illustrates and describes the front and back panel controls, ports, and LED indicators on the CE-511 and CE-566.

Front Panel Control Buttons

Figure 1-5 shows the Content Engine front panel, and Table 1-3 describes the front panel control buttons.

Figure 1-5 CE-511 and CE-566 Front Panel

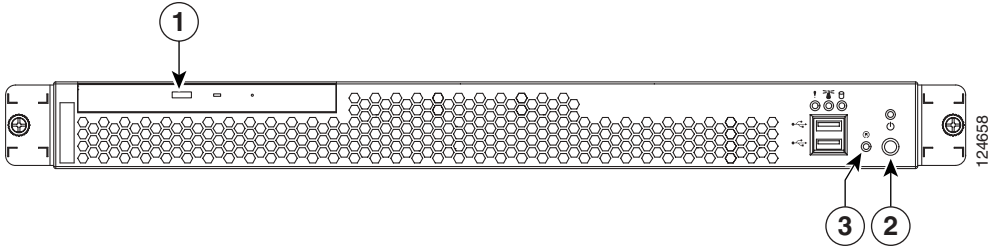

1	CD eject button	2	Power control button
3	Reset button		

Table 1-3 Front Panel Control Buttons

Item	Description
CD eject button	Releases a CD from the drive.
Power control button	Turns on the Content Engine.
Reset button	Resets the Content Engine and runs the power-on self-test (POST). You might need to use a pen or the end of a straightened paper clip to press the button. Note This is a hardware reset button and does not restore the device to the factory default software settings.

LED Indicators

Figure 1-6 shows the location of front panel LEDs, and Table 1-4 describes their function.

Figure 1-6 Front Panel LEDs

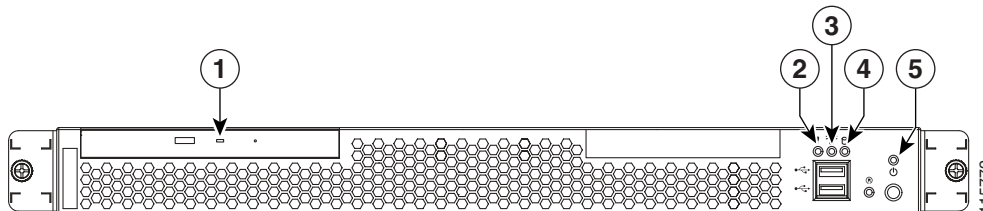

1	CD-ROM drive activity	2	System error
3	System locator (not supported on Content Engine models)	4	Hard disk drive activity
5	Power		

Table 1-4 Front Panel LEDs

LED	Color	State	Description
CD-ROM drive activity	Green	On	Indicates that the CD-ROM drive is in use.
System error	Amber	On	Indicates that a system error has occurred.
Hard disk drive activity	Green	Flashing	Indicates that the associated hard disk drive is in use.
Power	Green	On	Indicates that power is flowing to the Content Engine.
		Flashing	Indicates that the Content Engine is in standby mode.

Figure 1-7 shows the location of back panel LEDs, and Table 1-5 describes their function.

Figure 1-7 Back Panel LEDs

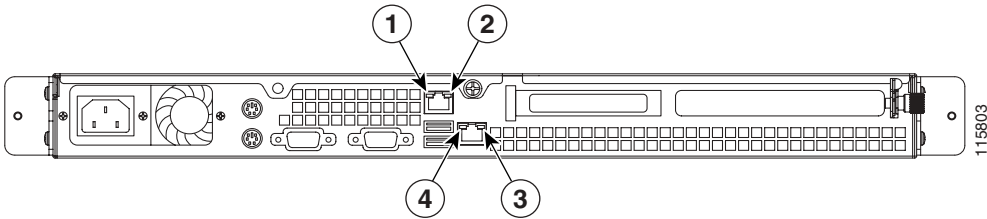

1	Ethernet 1 link	2	Ethernet 1 activity
3	Ethernet 2 activity	4	Ethernet 2 link

Table 1-5 Back Panel LEDs

Indicator	Color	State	Description
Ethernet 1 link	Green	On	Indicates that the speed of the Ethernet LAN is 1000BASE-TX.
		Off	Indicates that the speed of the Ethernet LAN is 10BASE-T/100BASE-TX.
Ethernet 1 activity	Green	Blinking	Indicates that there is an active link connection on the 10/100/1000BASE-T interface for Ethernet port 1.
Ethernet 2 activity	Green	Blinking	Indicates that there is an active link connection on the 10/100/1000BASE-T interface for Ethernet port 2.
Ethernet 2 link	Green	On	Indicates that the speed of the Ethernet LAN is 1000BASE-TX.
		Off	Indicates that the speed of the Ethernet LAN is 10BASE-T/100BASE-TX.

Figure 1-8 shows the LEDs for the Fibre Channel adapter, and Table 1-6 describes their function.

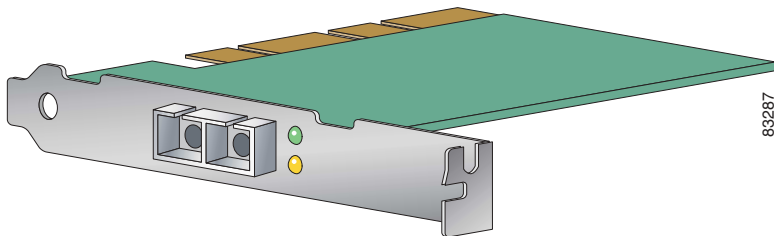
Figure 1-8 Fibre Channel Adapter LEDs**Note**

In the illustration, the top LED is green, and the bottom LED is amber.

Table 1-6 Fibre Channel Adapter LEDs

LED	State	Meaning
Green	On	Power is on.
Amber	On	
Green	On	Fibre Channel adapter is online.
Amber	Off	
Green	Off	Signal has been acquired. (The Fibre Channel adapter firmware is performing or waiting to perform Fibre Channel loop initialization.)
Amber	On	
Green	Off	Loss of synchronization.
Amber	Flashing	
Green	Flashing	Firmware error.
Amber	Flashing	

**Note**

The MPEG A/V decoder adapter does not have any LEDs.

Input/Output Ports and Connectors

Your Content Engine supports the following I/O connectors on the back of the device:

- Ethernet connectors
- Serial connector
- SCSI low-voltage differential (LVD) connector (CE-566 only)
- Fibre Channel connector (on optional adapter)
- Video and audio connectors (on optional adapter)



Warning

To avoid electric shock, do not connect safety extra-low voltage (SELV) circuits to telephone-network voltage (TNV) circuits. LAN ports contain SELV circuits, and WAN ports contain TNV circuits. Some LAN and WAN ports both use RJ-45 connectors. Use caution when connecting cables. Statement 1021

Figure 1-9 shows the location of the Content Engine back panel ports and receptacles.

Figure 1-9 CE-511 and CE-566 Back Panel Ports and Receptacles

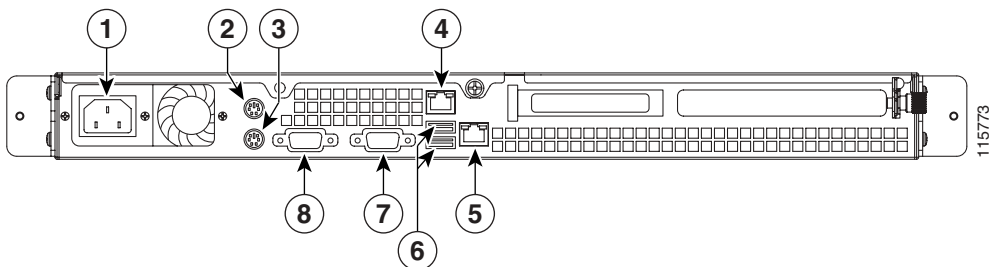

1	AC power receptacle	2	Mouse port
3	Keyboard port	4	Ethernet 1 receptacle
5	Ethernet 2 receptacle	6	USB ports (not supported)
7	Monitor port	8	Serial port

**Note**

Cisco ACNS software does not support the use of a keyboard or mouse (Personal System 2 [PS/2] or Universal Serial Bus [USB]) with the Content Engine. However, keyboard and mouse are supported by the BIOS for power-on self-test (POST), and the configuration/setup utility.

Table 1-7 describes the back panel ports and receptacles.

Table 1-7 Back Panel Ports and Connectors

Item	Description
AC power receptacle	The AC power cord connects to this plug.
Ethernet 1 port	This 10/100/1000BASE-T port is autosensing with full-duplex capability; it connects your Content Engine to the Ethernet LAN.
Ethernet 2 port	This 10/100/1000BASE-T port is autosensing with full-duplex capability; it connects your Content Engine to the Ethernet LAN.
Serial port	This is a standard serial port for connecting to a console or terminal.
SCSI LVD port (CE-566 only) (See Figure 1-2)	Use this port to attach an external Cisco Storage Array device.
Fibre Channel port (on optional adapter)	This port provides the option to connect to an external Fibre Array device or SAN ¹ for added data storage capacity.
Audio/video port (on optional MPEG A/V decoder adapter)	<ul style="list-style-type: none"> • 3 BNC² connectors for YUV, RGB³, and composite video output • Mini-XLR 8-pin connector for S/PDIF⁴ and analog stereo audio output • Mini-XLR 8-pin connector for VGA⁵ output

1. SAN = storage area network
2. BNC = Bayonet Neill-Concelman
3. RGB = red green blue
4. S/PDIF = Sony/Philips Digital Interface
5. VGA = video graphics array

Ethernet Port

The Content Engine comes with one integrated dual-port Ethernet controller. This controller provides an interface for connecting to 10-Mbps, 100-Mbps, or 1000-Mbps networks and provides full-duplex (FDX) capability, which enables simultaneous transmission and reception of data on the Ethernet LAN.

To access the Ethernet port, connect a Category 3, 4, or 5 unshielded twisted-pair (UTP) cable to the RJ-45 connector on the back of the device.



Note

The 100BASE-TX/1000BASE-TX Ethernet standard requires that the cabling in the network be Category 5 or higher.

Ethernet Port Connector

Figure 1-10 shows the pin number assignments for the Ethernet RJ-45 port.

Figure 1-10 Ethernet Port Connector

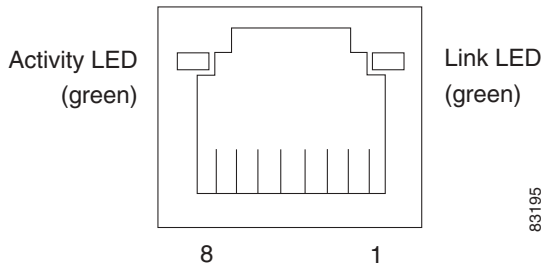

Serial Port

The Content Engine has one standard serial port connector located on the back of the device.

Serial Port Connector

Figure 1-11 shows the pin number assignments for the 9-pin, male D-shell serial port connector on the back of the device. These pin number assignments conform to the industry standard.

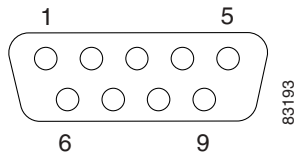
Figure 1-11 Serial Port Connector

SCSI Port

The CE-566 has one SCSI LVD port connector located on the back of the device. A cable for this port is provided when you purchase a Cisco Storage Array.

When you attach an external SCSI device to the SCSI connector, you must set a unique ID for the device. Refer to the information that comes with the device for instructions on how to set its SCSI ID.

SCSI Connector

[Figure 1-12](#) shows a 68-pin, female D-shell SCSI connector. These connectors conform to the SCSI standard.

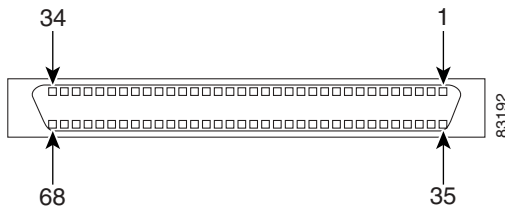
Figure 1-12 SCSI Port Connector

Fibre Channel Port

The CE-511 and CE-566 support one optional Fibre Channel adapter that has a single Fibre Channel port.

Fibre Channel Connector

The Fibre Channel connector (see [Figure 1-13](#)) is an LC-style connector that supports nonoptical fibre conductive (nonOFC), multimode fiber-optic cabling using a small form factor (SFF) fiber-optic transceiver module. The Fibre Channel adapter uses LC-LC Fibre Channel cables. The total cable length should not exceed 1640 feet (500 meters). Fibre Channel cables are not supplied by Cisco Systems.

Figure 1-13 *Fibre Channel Connector*

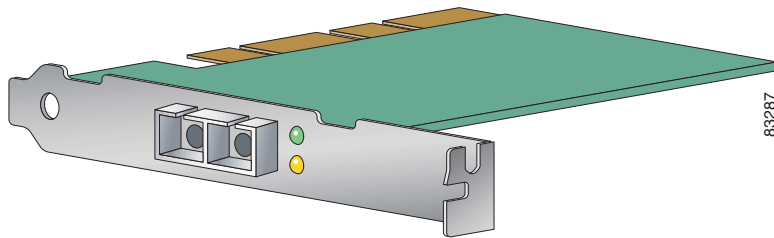

Video Port

The CE-511 and CE-566 support one optional MPEG A/V decoder adapter that has one audio and video input/output port.

Video Connectors

[Figure 1-14](#) shows the following five connectors for the audio and video input/output port:

- 3 BNC connectors for YUV, RGB, and composite video output
- Mini-XLR 8-pin connector for Sony/Philips Digital Interface (S/PDIF) and analog stereo audio output
- Mini-XLR 8-pin connector for video graphics array (VGA) output

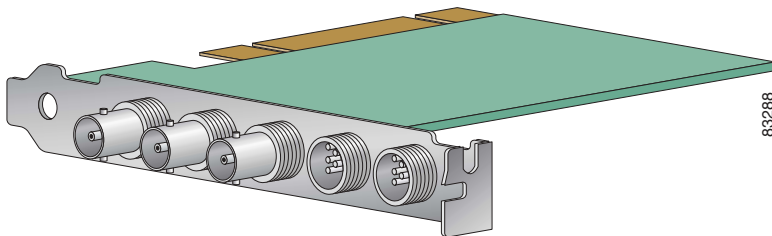
Figure 1-14 Video Input/Output Connectors

[Table 1-8](#) provides the pinout for the audio output mini-XLR 8-pin connector, and [Table 1-9](#) provides the pinout for the VGA output mini-XLR 8-pin connector.

Table 1-8 Audio Output Connector Pinout

Pin Number.	Destination
1	Audio left (-)
2	Ground
3	Audio left (+)
4	Audio right (+)
5	Ground
6	Audio left (-)
7	Ground
8	S/PDIF

Table 1-9 VGA Output Connector Pinout

Pin Number	Destination
1	Vsync
2	Ground
3	Hsync
4	Blue
5	Ground

Table 1-9 VGA Output Connector Pinout (continued)

Pin Number	Destination
6	Red
7	Green
8	Ground

Specifications

Table 1-10 summarizes the features and specifications for the CE-511 and CE-566.

Table 1-10 CE-511 and CE-566 Hardware Specifications

Specification	Description
Microprocessor	1 Intel 2.8-GHz Celeron 256-KB with Level 2 cache and multimedia extensions (MMX2) technology
Expansion bays	Two 3.5-in. (8.89-cm) slim-height bays for hard disk drives
Expansion slots	Two 66-/100-/133-MHz 64-bit PCI-X slots on the system board (half-length full-height slots; one low-profile and one full profile)
Hard disk controller	<ul style="list-style-type: none"> CE-511—Serial advanced technology attachment (ATA) controller CE-566—Ultra320 SCSI controller
Adapters	<ul style="list-style-type: none"> 1-port Fibre Channel adapter 1-port MPEG A/V decoder adapter <p>Note The CE-511 and CE-566 support either the Fibre Channel adapter or the MPEG A/V decoder adapter in PCI slot 1.</p> <ul style="list-style-type: none"> Ultra320 SCSI adapter installed in PCI slot 2 (CE-566 only)

Table 1-10 CE-511 and CE-566 Hardware Specifications (continued)

Specification	Description
Fibre Channel adapter	<ul style="list-style-type: none"> • Bus type: Fiber-optic media (shortwave 50-micron) • Bus transfer rate: 2 gigabits per second (Gbps) maximum at half duplex and 4 Gbps at full duplex • Protocols: Supports FCP¹-SCSI protocol
MPEG A/V decoder adapter	<p>Video specifications</p> <ul style="list-style-type: none"> • S/N:² 10 kHz to 4.2 MHz; Y: 65 dB rms³; Pb: 70 dB rms; Pr: 70 dB rms • Frequency response: 0 to 4.0 MHz \pm 2 dB • Sync tip: 40 IRE⁴ \pm 4 • Luma nonlinearity: 5% • Audio specifications <ul style="list-style-type: none"> • S/PDIF⁵ <ul style="list-style-type: none"> – PCM⁶ or compressed audio coding 3 (AC-3) bitstream out – 75-ohm, 0.5-V p-p⁷ \pm 20% – Rise and fall time: > 0.4 microseconds measured from 10 to 90% • Analog <ul style="list-style-type: none"> – Jumper-selectable balanced or unbalanced audio (balanced = +4 dBm) – Frequency response: 20 Hz to 22 kHz \pm 0.5 dB – Reference level: 0.5-V p-p \pm 10% – THD⁸+n:@20 Hz to 22 kHz < 0.5%
Power supply	1 AC-input

Table 1-10 *CE-511 and CE-566 Hardware Specifications (continued)*

Specification	Description
Dimensions	<ul style="list-style-type: none"> • Height: 1.75 in., 1 RU (44 mm) • Depth: 20 in. (508 mm) • Width: 16.69 in. (430 mm)
Weight	Maximum weight: 28 lb (12.7 kg) depending on your configuration
Electrical input	<ul style="list-style-type: none"> • Sine-wave input (47–63 Hz) required • Input voltage low range: <ul style="list-style-type: none"> – Minimum: 100 VAC – Maximum: 127 VAC • Input voltage high range: <ul style="list-style-type: none"> – Minimum: 200 VAC – Maximum: 240 VAC • Input kilovolt-amperes (kVA), approximately: <ul style="list-style-type: none"> – Minimum: 0.20 kVA – Maximum: 0.45 kVA
Ports	<ul style="list-style-type: none"> • 1000BASE-TX, 100BASE-TX, 10BASE-T (dual) Ethernet ports • Serial port • 2 USB ports • Ultra320 SCSI port (CE-566 only) • Fibre Channel port (on optional adapter) • Audio/video ports (on optional adapter): <ul style="list-style-type: none"> – 3 BNC connectors – 2 mini-XLR connectors

Table 1-10 *CE-511 and CE-566 Hardware Specifications (continued)*

Specification	Description
Temperature	<ul style="list-style-type: none"> Operating: 50 to 95° F (10 to 35° C) Nonoperating: -40 to 140° F (-40 to +60° C)
Heat Dissipation	<ul style="list-style-type: none"> Minimum configuration: 307 Btu⁹/hr (90 Watts) Maximum configuration: 850 Btu/hr (250 Watts)
Humidity	<ul style="list-style-type: none"> Operating: 8 to 80% Nonoperating: 8 to 80%
Altitude	Maximum altitude: 6998 ft (2133 m)
Acoustical noise emissions	<ul style="list-style-type: none"> Sound power, idling: 6.5 bel maximum Sound power, operating: 6.5 bel maximum

1. FCP = Fibre Channel Protocol
2. S/N = signal-to-noise ratio
3. rms = root mean square
4. IRE = Institute of Radio Engineers
5. S/PDIF = Sony/Philips Digital Interface
6. PCM = pulse-coded modulation
7. p-p = peak to peak
8. THD = total harmonic distortion
9. Btu = British thermal unit

Regulatory Compliance

[Table 1-11](#) lists regulatory compliance and agency approvals for the CE-511 and CE-566.

Table 1-11 Regulatory Compliance

Item	Description
Compliance	CE Marking
Safety	UL 1950 CSA-C22.2 No. 950 EN 60950 IEC 60950
EMC	FCC Part 15 (CFR 47) Class A ICES-003 Class A EN 55022 Class A with UTP cables CISPR22 Class A with UTP cables AS/NZS 3548 Class A with UTP cables VCCI Class A with UTP cables EN 55024 EN 50082-1

Class A Warning Statements

VCCI Class A Warning for Japan



Warning

This is a Class A product based on the standard of the Voluntary Control Council for Interference by Information Technology Equipment (VCCI). If this equipment is used in a domestic environment, radio disturbance may arise. When such trouble occurs, the user may be required to take corrective actions. Statement 191

警告

これは、情報処理装置等電波障害自主規制協議会（VCCI）の規定に基づくクラスA装置です。この装置を家庭環境で使用すると、電波妨害を引き起こすことがあります。この場合には、使用者が適切な対策を取るようにより要求されることがあります。

Class A Notice for Taiwan and Other Traditional Chinese Markets



Warning

This is a Class A Information Product, when used in residential environment, it may cause radio frequency interference, under such circumstances, the user may be requested to take appropriate countermeasures. Statement 257

警告

這是甲類資訊產品，在居住環境中使用時，可能會造成射頻干擾，在這種情況下，使用者會被要求採取某些適當的對策。

Class A Warning for Hungary



Warning

This equipment is a class A product and should be used and installed properly according to the Hungarian EMC Class A requirements (MSZEN55022). Class A equipment is designed for typical commercial establishments for which special conditions of installation and protection distance are used.

Statement 256

Figyelem

Figyelmeztetés a felhasználói kézikönyv számára: Ez a berendezés "A" osztályú termék, felhasználására és üzembe helyezésére a magyar EMC "A" osztályú követelményeknek (MSZ EN 55022) megfelelően kerülhet sor, illetve ezen "A" osztályú berendezések csak megfelelő kereskedelmi forrásból származhatnak, amelyek biztosítják a megfelelő speciális üzembe helyezési körülményeket és biztonságos üzemelési távolságok alkalmazását.



Preparing to Install the Content Engine

This chapter contains important safety information you should know before working with the Content Engine. Use the following guidelines to ensure your own personal safety and to help protect your Content Engine from potential damage.

This chapter contains the following sections:

- [Safety Warnings, page 2-1](#)
- [Safety Guidelines, page 2-4](#)



Note

Read the *Regulatory Compliance and Safety Information for the Cisco Content Networking Product Series* document that came with your Content Engine before you begin the installation.

Safety Warnings

Before you install the Content Engine, observe the following safety warnings.



Warning

Only trained and qualified personnel should be allowed to install, replace, or service this equipment. Statement 1030

**Warning**

Read the installation instructions before connecting the system to the power source. Statement 1004

**Warning**

Before working on a system that has an on/off switch, turn OFF the power and unplug the power cord. Statement 1

**Warning**

This unit might have more than one power supply connection. All connections must be removed to de-energize the unit. Statement 1028

**Warning**

This unit is intended for installation in restricted access areas. A restricted access area is where access can only be gained by service personnel through the use of a special tool, lock and key, or other means of security, and is controlled by the authority responsible for the location. Statement 37

**Warning**

To avoid electric shock, do not connect safety extra-low voltage (SELV) circuits to telephone-network voltage (TNV) circuits. LAN ports contain SELV circuits, and WAN ports contain TNV circuits. Some LAN and WAN ports both use RJ-45 connectors. Use caution when connecting cables. Statement 1021

**Warning**

This product relies on the building's installation for short-circuit (overcurrent) protection. Ensure that a fuse or circuit breaker no larger than 120 VAC, 15A U.S. (240 VAC, 10A international) is used on the phase conductors (all current-carrying conductors). Statement 13

**Warning**

This equipment must be grounded. Never defeat the ground conductor or operate the equipment in the absence of a suitably installed ground conductor. Contact the appropriate electrical inspection authority or an electrician if you are uncertain that suitable grounding is available. Statement 1024

**Warning**

Do not work on the system or connect or disconnect cables during periods of lightning activity. Statement 1001

**Warning**

Before working on equipment that is connected to power lines, remove jewelry (including rings, necklaces, and watches). Metal objects will heat up when connected to power and ground and can cause serious burns or weld the metal object to the terminals. Statement 43

**Warning**

When installing or replacing the unit, the ground connection must always be made first and disconnected last. Statement 1046

**Warning**

The safety cover is an integral part of the product. Do not operate the unit without the safety cover installed. Operating the unit without the cover in place will invalidate the safety approvals and pose a risk of fire and electrical hazards. Statement 117

**Warning**

Blank faceplates and cover panels serve three important functions: they prevent exposure to hazardous voltages and currents inside the chassis; they contain electromagnetic interference (EMI) that might disrupt other equipment; and they direct the flow of cooling air through the chassis. Do not operate the system unless all cards, faceplates, front covers, and rear covers are in place. Statement 1029

**Warning**

There is the danger of explosion if the battery is replaced incorrectly. Replace the battery only with the same or equivalent type recommended by the manufacturer. Dispose of used batteries according to the manufacturer's instructions. Statement 1015

**Warning**

Ultimate disposal of this product should be handled according to all national laws and regulations. Statement 1040

**Warning**

To prevent bodily injury when mounting or servicing this unit in a rack, you must take special precautions to ensure that the system remains stable. The following guidelines are provided to ensure your safety:

- **This unit should be mounted at the bottom of the rack if it is the only unit in the rack.**
 - **When mounting this unit in a partially filled rack, load the rack from the bottom to the top with the heaviest component at the bottom of the rack.**
 - **If the rack is provided with stabilizing devices, install the stabilizers before mounting or servicing the unit in the rack.** Statement 1006
-

Safety Guidelines

To reduce the risk of bodily injury, electrical shock, fire, and damage to the equipment, observe the following precautions.

General Precautions

Observe the following general precautions for using and working with your system:

- Observe and follow service markings. Do not service any Cisco product except as explained in your system documentation. Opening or removing covers that are marked with the triangular symbol with a lightning bolt may expose you to electrical shock. Components inside these compartments should be serviced only by an authorized service technician.
- If any of the following conditions occur, unplug the product from the electrical outlet and replace the part or contact your authorized service provider:
 - The power cable, extension cord, or plug is damaged.
 - An object has fallen into the product.

- The product has been exposed to water.
 - The product has been dropped or damaged.
 - The product does not operate correctly when you follow the operating instructions.
- Keep your system components away from radiators and heat sources. Also, do not block cooling vents.
- Do not spill food or liquids on your system components, and never operate the product in a wet environment.
- Do not push any objects into the openings of your system components. Doing so can cause fire or electric shock by shorting out interior components.
- Use the product only with other Cisco-approved equipment.
- Allow the product to cool before removing covers or touching internal components.
- Use the correct external power source. Operate the product only from the type of power source indicated on the electrical ratings label. If you are not sure of the type of power source required, consult your service representative or local power company.
- Use only approved power cables. If you have not been provided with a power cable for your Content Engine or for any AC-powered option intended for your system, purchase a power cable that is approved for use in your country. The power cable must be rated for the product and for the voltage and current marked on the product's electrical ratings label. The voltage and current rating of the cable should be greater than the ratings marked on the product.
- To help prevent electric shock, plug the system components and peripheral power cables into properly grounded electrical outlets. These cables are equipped with three-prong plugs to help ensure proper grounding. Do not use adapter plugs or remove the grounding prong from a cable. If you must use an extension cord, use a three-wire cord with properly grounded plugs.
- Observe extension cord and power strip ratings. Make sure that the total ampere rating of all products plugged into the extension cord or power strip does not exceed 80 percent of the extension cord or power strip ampere ratings limit.
- Do not use appliance or voltage converters or kits sold for appliances with your product.

- To help protect your system components from sudden, transient increases and decreases in electrical power, use a surge suppressor, line conditioner, or uninterruptible power supply (UPS).
- Position cables and power cords carefully; route cables and the power cord and plug so that they cannot be stepped on or tripped over. Be sure that nothing rests on your system components' cables or power cord.
- Do not modify power cables or plugs. Consult a licensed electrician or your power company for site modifications. Always follow your local or national wiring rules.

Protecting Against Electrostatic Discharge

Static electricity can harm delicate components inside the Content Engine. To prevent static damage, discharge static electricity from your body before you touch any of your system's electronic components. You can do so by touching an unpainted metal surface on the chassis.

You can also take the following steps to prevent damage from electrostatic discharge (ESD):

- When unpacking a static-sensitive component from its shipping carton, do not remove the component from the antistatic packing material until you are ready to install the component in your system. Just before unwrapping the antistatic packaging, be sure to discharge static electricity from your body.
- When transporting a sensitive component, first place it in an antistatic container or packaging.
- Handle all sensitive components in a static-safe area. If possible, use antistatic floor pads and workbench pads.

Rack Installation Safety Guidelines

Before installing your Content Engine in a rack, review the following guidelines:

- Two or more people are required to install the device in a rack.
- Ensure that the room air temperature is below 95°F (35°C).
- Do not block any air vents; usually 6 inches (15 cm) of space provides proper airflow.

- Plan the device installation starting from the bottom of the rack.
- Install the heaviest device in the bottom of the rack.
- Do not extend more than one device out of the rack at the same time.
- Remove the rack doors and side panels to provide easier access during installation.
- Connect the Content Engine to a properly grounded outlet.
- Do not overload the power outlet when installing multiple devices in the rack.
- Do not place any object weighing more than 110 lb (50 kg) on top of rack-mounted devices.



Installing the Content Engine

This chapter explains how to install CE-511 and CE-566 in an equipment rack. It also provides general instructions for installing CE-511 and CE-566 on a table or workbench. This chapter contains the following sections:

- [Tools and Parts Required, page 3-1](#)
- [Installing a CE-511 or CE-566 Unit, page 3-2](#)
- [Connecting Cables, page 3-12](#)
- [Connecting Power and Booting the System, page 3-13](#)
- [Checking the LEDs, page 3-14](#)
- [Removing or Replacing a Content Engine, page 3-14](#)

Before you begin the installation, read the *Regulatory Compliance and Safety Information for the Cisco Content Networking Product Series* document that shipped with your chassis.



Warning

Read the installation instructions before connecting the system to the power source. Statement 1004

Tools and Parts Required

A sliding rail rack-mount kit and cable management assembly is included in your shipping container accessory box. The rack-mount kit is suitable for mounting CE-511 and CE-566 units in 19-inch (48.26-cm) 4-post equipment racks.

Angle brackets for mounting CE-511 and CE-566 units in a 2-post rack are also included in your shipping container accessory box.

You need the following parts and tools to install the Content Engine in a rack:

- Flat-blade screwdriver
- Phillips screwdriver
- One rack-mount kit
- Documentation

Installing a CE-511 or CE-566 Unit

Place the unit in the desired location. You can mount it in a rack for your convenience, or place it on a solid, stable surface. If you do not plan to install the unit in an equipment rack, proceed to the [“Installing the Chassis on a Tabletop” section on page 3-11](#).

Racks are marked in vertical increments of 1.75 inches (4.44 cm). Each increment is referred to as a rack unit (RU). A 1-RU device is 1.75 inches (4.44 cm) tall.



Warning

To prevent bodily injury when mounting or servicing this unit in a rack, you must take special precautions to ensure that the system remains stable. The following guidelines are provided to ensure your safety:

- **This unit should be mounted at the bottom of the rack if it is the only unit in the rack.**
 - **When mounting this unit in a partially filled rack, load the rack from the bottom to the top with the heaviest component at the bottom of the rack.**
 - **If the rack is provided with stabilizing devices, install the stabilizers before mounting or servicing the unit in the rack.** Statement 1006
-

Installing the Chassis in a 2-Post Rack

The Content Engine mounts to two rack posts with brackets that attach to the sides of the chassis. These brackets are for a 19-inch (48.26-cm) equipment rack and require four rack screws in each bracket. (See [Figure 3-1](#).)

Figure 3-1 *Rack-Mount Brackets*

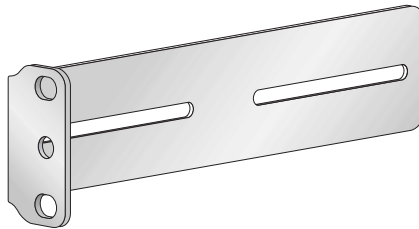

Orientation for 19-inch rack

124554

To install a Content Engine in a 2-post rack, follow these steps:

- Step 1** Attach a bracket to one side of the chassis, aligning the front flange of the bracket with the hash mark on the side of the chassis. (See [Figure 3-2](#).)

Figure 3-2 Installing the Chassis in the Rack

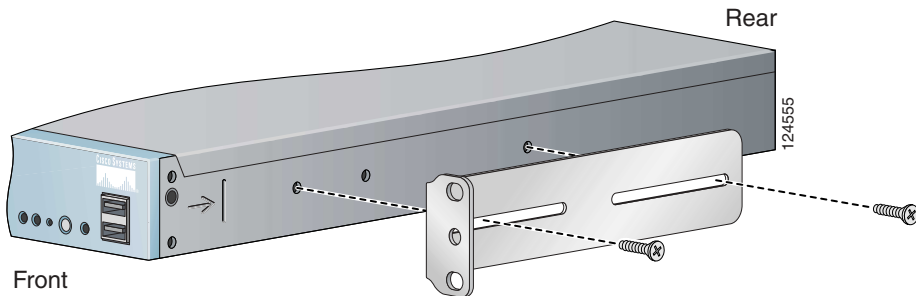

- Step 2** Attach a second bracket to the opposite side of the chassis in the same manner.
- Step 3** After you secure the brackets to the chassis, rack-mount the chassis by securing the brackets to two posts or mounting strips in the rack. You need two people to install the chassis in the rack—one person to hold the chassis and one person to secure it to the rack.

The inlet and exhaust ports for cooling air are located in the front and rear of the chassis, respectively; therefore, multiple Content Engines can be stacked with little or no vertical clearance.

Installing the Chassis in a 4-Post Rack

[Figure 3-3](#) shows the items that you need to install the Content Engine in a 4-post rack. If any items are missing or damaged, contact your place of purchase.

Figure 3-3 Rack Installation Kit

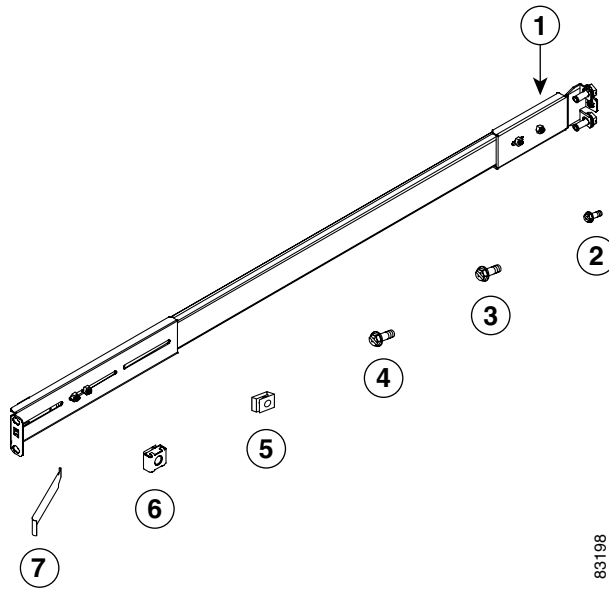

83198

1	Slide rail assemblies (2)	2	M3.5 screws with lock washers (3)
3	M4 screws (6)	4	M6 screws (10)
5	Clip nuts (10)	6	Cage nuts (10)
7	Cage nut insertion tool (1)		

**Note**

The right and left slide rails are identical.

To install the CE-511 and CE-566 in the 4-post rack, follow these steps:

- Step 1** Select a 1-RU-size location in the rack. Starting with the right front side of the rack (as viewed from the front of the Content Engine), install a clip nut or cage nut in the top and bottom positions of the 1-RU location that you selected (see [Figure 3-4](#)) and then install a clip nut or cage nut in the corresponding positions on the rear of the rack. Repeat this step for the left front side of the rack and the corresponding location on the rear of the rack.

Figure 3-4 Installing Clip Nuts or Cage Nuts

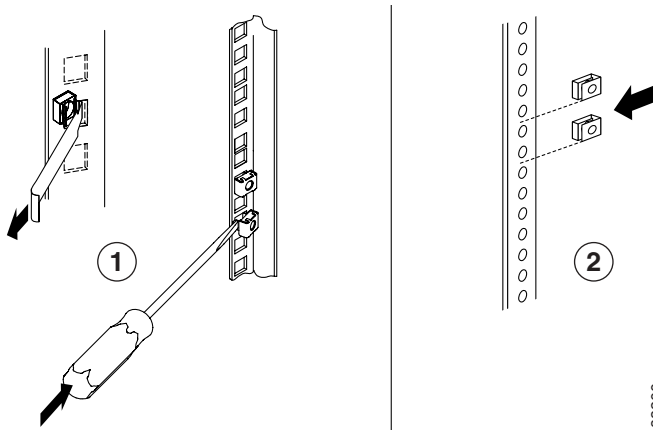

83200

1	Cage nuts	2	Clip nuts
---	-----------	---	-----------

- Step 2** Remove the inner slide rails from the slide rail assemblies by pressing the release latches on the sides of the slide rail assemblies. (See [Figure 3-5](#).)

Figure 3-5 Removing the Inner Slide Rail

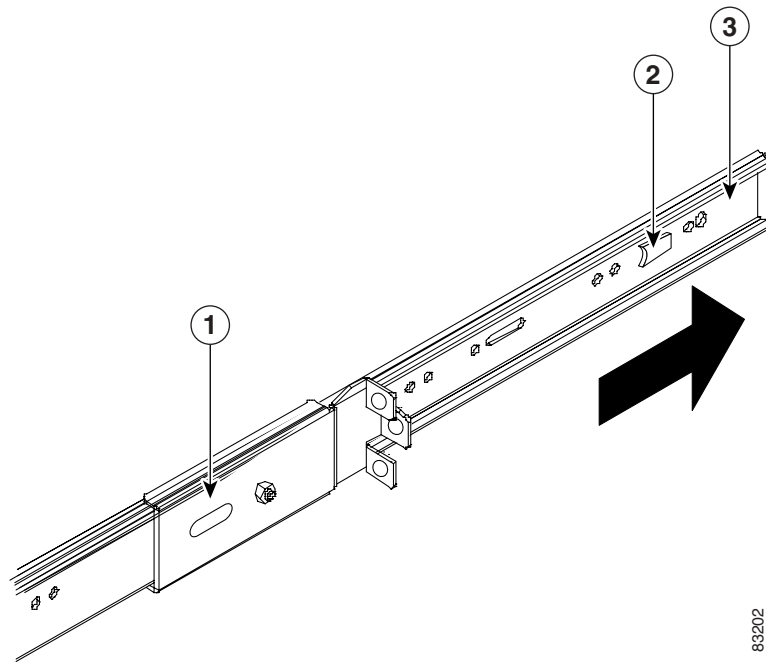

83202

1	Slide rail assembly	2	Release latch
3	Inner slide rail		

Step 3 Place an inner slide rail at the alignment marker (labeled 1 in [Figure 3-6](#)) as indicated by the arrow on the side of the Content Engine. Use two M4 screws to secure the inner slide rail to the Content Engine.

Repeat this step to attach the other inner slide rail to the Content Engine.

Figure 3-6 Attaching the Inner Slide Rail to the Content Engine

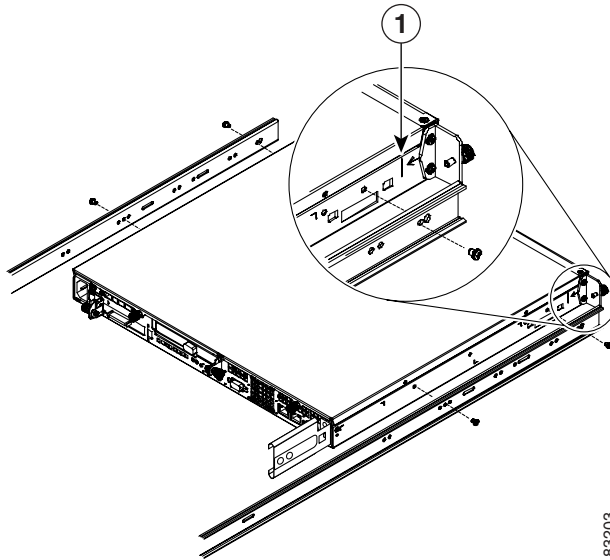

- Step 4** Insert the tab (labeled 1 in [Figure 3-7](#)) on the rear of the slide rail assembly through the center hole between the two clip nuts or cage nuts on the rear flange.

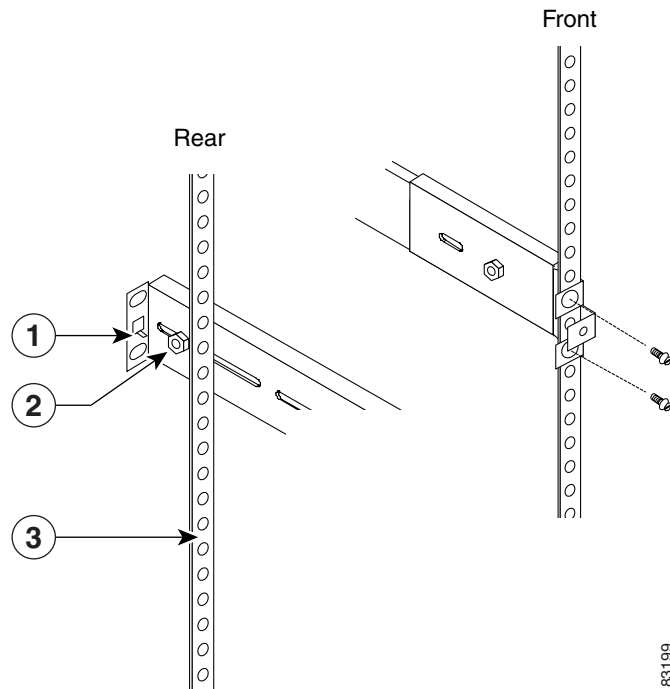
Figure 3-7 Attaching the Slide Rails to the Rack

1	Tab	2	Adjustment screw
3	Rear flange		

Step 5 Align the slide rail assembly to the front flange on the rack, and insert and tighten two M6 screws to secure the slide rail to the front flange. (See [Figure 3-7](#).)

Repeat [Step 4](#) and [Step 5](#) to install the other slide rail assembly.



Note If it is necessary to adjust the length of the slide rail, loosen the adjustment screw (labeled 2 in [Figure 3-7](#)) on the rear of the slide rail; then adjust the length of the slide rail and tighten the adjustment screw.

- Step 6** Align and insert the inner slide rails into the slide rail assemblies until they lock into place.
- Step 7** Slide the Content Engine into the rack until the Content Engine locks into place.
- Step 8** Tighten the captive screw (labeled 1 in [Figure 3-8](#)) on each side of the front of the Content Engine to secure the Content Engine to the rack.

Figure 3-8 *Inserting the Inner Slide Rails*

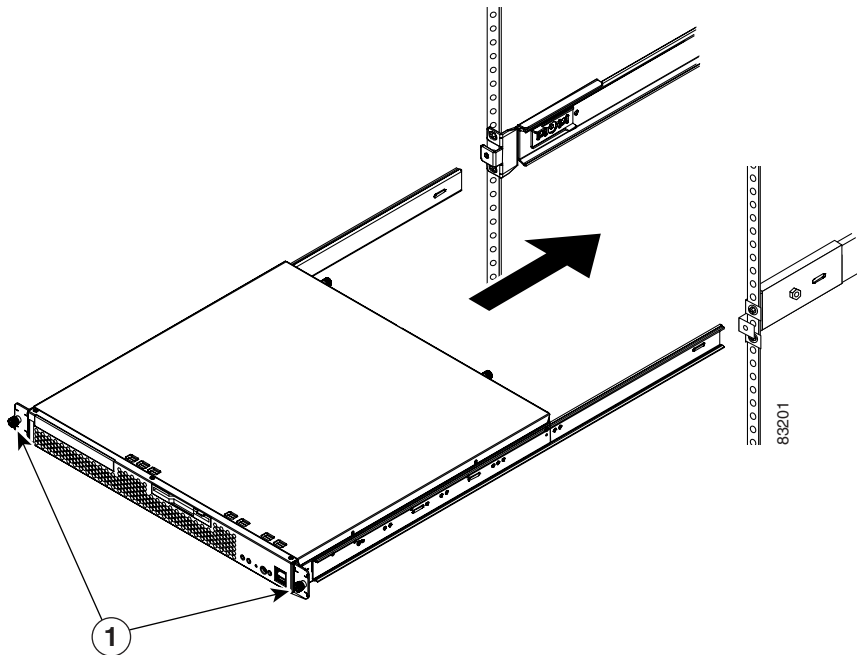

- Step 9** Attach the power cords and the Ethernet cables to the Content Engine.
- Because the Content Engine does not contain cable retention brackets or cable strain relief brackets, you must first bundle the external cables before you route them.



Note Leave enough slack in the cables to allow for sliding the Content Engine in or out of the rack.

To remove the Content Engine from the rack, reverse these instructions. Store these installation instructions with your Content Engine documentation for future use.

Installing the Chassis on a Tabletop

When you install a Content Engine on a workbench or tabletop, ensure that the surface is clean and in a safe location and that you have considered the following:

- The chassis should be installed off the floor. (Dust that accumulates on the floor is drawn into the interior of the chassis by the cooling fans. Excessive dust inside the Content Engine can cause overtemperature conditions and component failures.)
- There must be approximately 19 inches (48.26 cm) of clearance at the front and rear of the chassis for accessing network cables or equipment.
- The Content Engine must receive adequate ventilation (it is not being installed in an enclosed cabinet where ventilation is inadequate).

Follow these steps to install the Content Engine on a workbench or tabletop:

-
- Step 1** Remove any debris and dust from the tabletop or workbench, as well as from the surrounding area. Also make sure that your path between the Content Engine and its new location is unobstructed.
- Step 2** Attach the rubber feet to the bottom of the chassis. The rubber feet have an adhesive backing. Peel the protective tape off the adhesive and stick the feet to the bottom of a clean chassis surface. Place one foot in each corner.
- Step 3** Place the chassis on the tabletop or workbench.
- Step 4** Ensure that no exhaust air from other equipment will be drawn into the chassis. Also, ensure that there is adequate clearance at the front and rear of the chassis.
-

Connecting Cables

Follow these steps to connect network, console, and SCSI cables to the Content Engine.

**Note**

The SCSI cable is part of the Cisco Storage Array accessory kit. If you did not order the Cisco Storage Array, you did not receive a SCSI cable.

-
- Step 1** For network connections, insert a Category 5 UTP cable into the Ethernet 1 or Ethernet 2 receptacle on the Content Engine back panel. (See [Figure 3-9](#).)
- Step 2** Connect the other end of the network cable to a hub or switch in your network.
- Step 3** For console connections, plug the serial cable into the serial port on the Content Engine back panel.
- Step 4** Connect the other end of the console cable to a console or a communications server.
- Step 5** If you are using a Cisco Storage Array as an external storage device, attach the SCSI cable to the SCSI LVD port.

**Caution**

Make sure to tighten the jackscrews on the SCSI cable.

**Note**

SCSI port is available only on CE-566 model.

- Step 6** Connect the other end of the SCSI cable to the appropriate port on the Storage Array.

For further information about the Cisco Storage Array, refer to the *Cisco Storage Array Installation and Configuration Guide* publications.

Figure 3-9 CE-511 and CE-566 Back Panel Ports and Receptacles

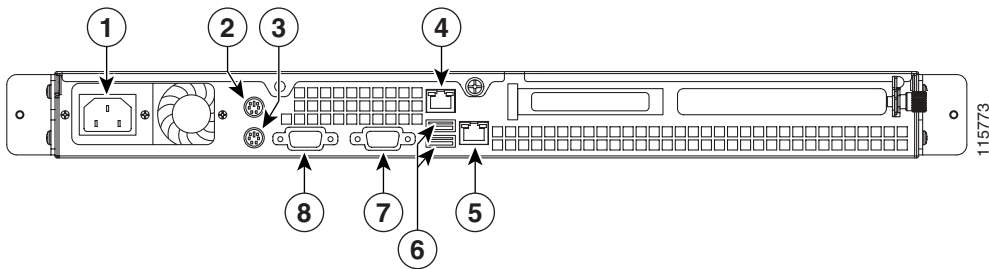

1	AC power receptacle	2	Mouse connector
3	Keyboard connector	4	Ethernet 1 receptacle
5	Ethernet 2 receptacle	6	USB ports (not supported)
7	Video connector	8	Serial connector

**Note**

Cisco ACNS software does not support the use of a keyboard or mouse (PS/2 or USB) with the Content Engine. However, keyboard and mouse are supported by the BIOS for power-on self-test (POST), and the configuration/setup utility.

Connecting Power and Booting the System

Follow these steps to connect power to the Content Engine:

- Step 1** Review the information in the [“Safety Warnings” section on page 2-1](#).
- Step 2** Plug the AC power cord into the power cord receptacle at the rear of the Content Engine. (See [Figure 3-9](#).)
- Step 3** Connect the other end of the power cord to a power source at your installation site.

Step 4 Power up all externally connected devices.

Step 5 Press the power control button on the front of the Content Engine.

The system should begin booting. Once the operating system boots, you are ready to initialize the basic software configuration. (Refer to the software configuration guide or user guide that shipped with your system.)



Note While the Content Engine is powering up, the green power on LED on the front of the Content Engine is on.



Note You can install a circular disk over the power control button to prevent accidental manual power down. This disk, known as the power control button shield, comes with the Content Engine.

Checking the LEDs

When the Content Engine is up and running, observe the front panel LEDs. (See the [“LED Indicators”](#) section on page 1-8 to verify that your system is operating properly.)

Removing or Replacing a Content Engine



Warning

Before working on a system that has an on/off switch, turn OFF the power and unplug the power cord. Statement 1



Warning

Ultimate disposal of this product should be handled according to all national laws and regulations. Statement 1040

To remove a Content Engine from your network, power it down, disconnect the power cords and network cables, and physically remove the chassis from the rack.

The Content Engine is in constant communication with the router on your network; thus, when the router notices that the Content Engine is no longer responding to it, the router stops sending requests to the Content Engine. This is transparent to users. If other Content Engines are attached to the router, the router continues sending requests to the other Content Engines.

When you remove a Content Engine, the pages that were cached on that device are no longer available to the router or other Content Engines. Thus, you might see an increase in outgoing web traffic that might have otherwise been fulfilled by the Content Engine that you are removing. However, after a time, the router and other Content Engines redistribute the load of web traffic.

If you remove the last Content Engine from your network, you can also disable Content Engine support on the router. However, this is not necessary; having Content Engine support enabled when there are no Content Engines attached has no effect on the router's performance.

To replace a Content Engine, remove it from the network. Then, install a new Content Engine and configure it using the same configuration parameters (IP address, and so forth) that you used for the removed Content Engine.



Installing Hardware Options

This chapter provides basic instructions for installing hardware options in the Content Engine. These instructions are intended for technicians who are experienced with setting up Cisco Content Engine hardware.

This chapter contains the following topics:

- [Removing the Cover and Bezel, page 4-1](#)
- [Installing Adapters, page 4-3](#)
- [Working with Hard Disk Drives, page 4-12](#)
- [Completing the Installation, page 4-16](#)

Removing the Cover and Bezel



Warning

Before working on a system that has an on/off switch, turn OFF the power and unplug the power cord. Statement 1

Complete the following steps to remove the Content Engine cover:

-
- Step 1** Review the information in the [“Safety Warnings” section on page 2-1](#), and the [“Safety Guidelines” section on page 2-4](#).
- Step 2** Power down the Content Engine and all attached devices. Disconnect the power cord and all external cables.
- Step 3** Loosen the two captive screws (1) on the rear of the cover. (See [Figure 4-1](#).)

Figure 4-1 Removing the Content Engine Cover

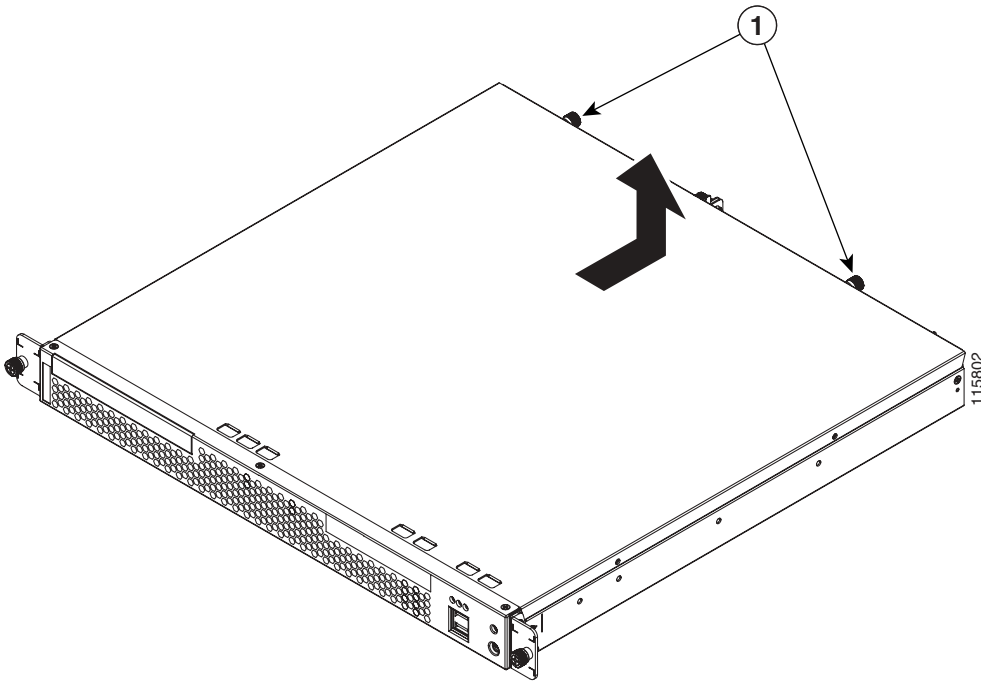

Step 4 Slide the cover back; then lift it up and off the Content Engine.



Caution For proper cooling and airflow, replace the cover before turning on the Content Engine. Operating the Content Engine for extended periods (over 30 minutes) with the cover removed might damage Content Engine components.

Step 5 Remove the bezel as shown in [Figure 4-2](#).

- a. Press the release tabs on the bezel and pull the bezel away from the Content Engine.
- b. Store the bezel in a safe place.

Figure 4-2 Removing the Content Engine Bezel

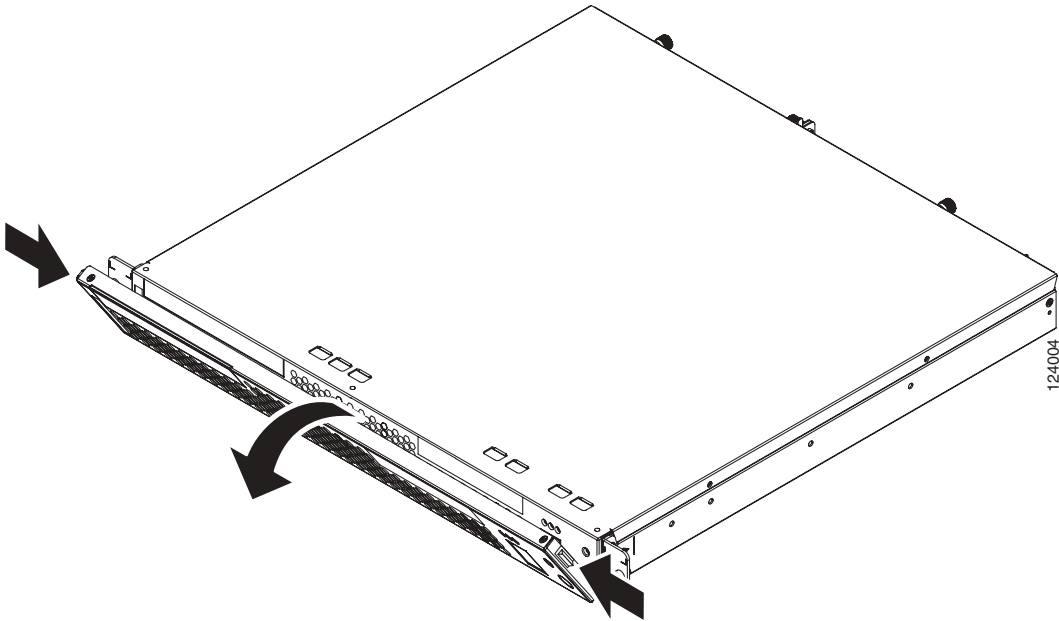

Installing Adapters

This section provides general information about the system board, riser card, adapter and PCI-X slot configuration specifications, and contains the following adapter installation procedures:

- [Installing an MPEG Decoder Adapter, page 4-5](#)
- [Preparing and Installing a Fibre Channel Adapter, page 4-8](#)

Before you install adapters, review the following:

- The Content Engine comes with two Peripheral Component Interconnect-Extended (PCI-X) adapter slots. PCI-X slot 1 is located on the adapter support bracket with the riser card. PCI-X slot 2 is located on the system board. To access the PCI-X slot 1 connector, you must first remove the adapter support bracket. (See [Figure 4-4](#).)
 - You can install either a Fibre Channel adapter or an MPEG A/V decoder adapter in PCI-X slot 1. (This slot is labeled “PCI 1” on the back of the Content Engine.)
 - The CE-566 has a SCSI adapter installed in PCI-X slot 2 (PCI 2). This adapter is not user-replaceable.
- Locate the documentation that comes with the adapter and follow those instructions in addition to the instructions in this chapter.
- The system scans PCI-X slots to assign system resources. By default the system tries to boot from the CD-ROM. If the CD-ROM is not present, the system boots from the integrated flash device.



Caution

When you handle static-sensitive devices, take precautions to avoid damage from static electricity. For details on handling these devices, see the [“Protecting Against Electrostatic Discharge”](#) section on page 2-6.

Installing an MPEG Decoder Adapter

Complete the following steps to install an MPEG decoder adapter.

**Note**

The illustrations in this document might differ slightly from your hardware.

- Step 1** Review the safety information in the [“Safety Guidelines” section on page 2-4](#).
- Step 2** Power down the Content Engine and peripheral devices.
- Step 3** Disconnect the power cord and then all external cables from the Content Engine.
- Step 4** Remove the Content Engine cover.

**Note**

It might be easier to route the cables before you install the adapter.

- Step 5** Loosen the captive screw (labeled 4 in [Figure 4-3](#)) located on the rear of the Content Engine adjacent to PCI-X slot 1 and remove the expansion slot cover.

**Note**

PCI expansion slot covers must be installed on all vacant slots. This maintains the electronic emissions characteristics of the Content Engine and ensures proper cooling of Content Engine components.

Figure 4-3 Removing the Expansion Slot Cover

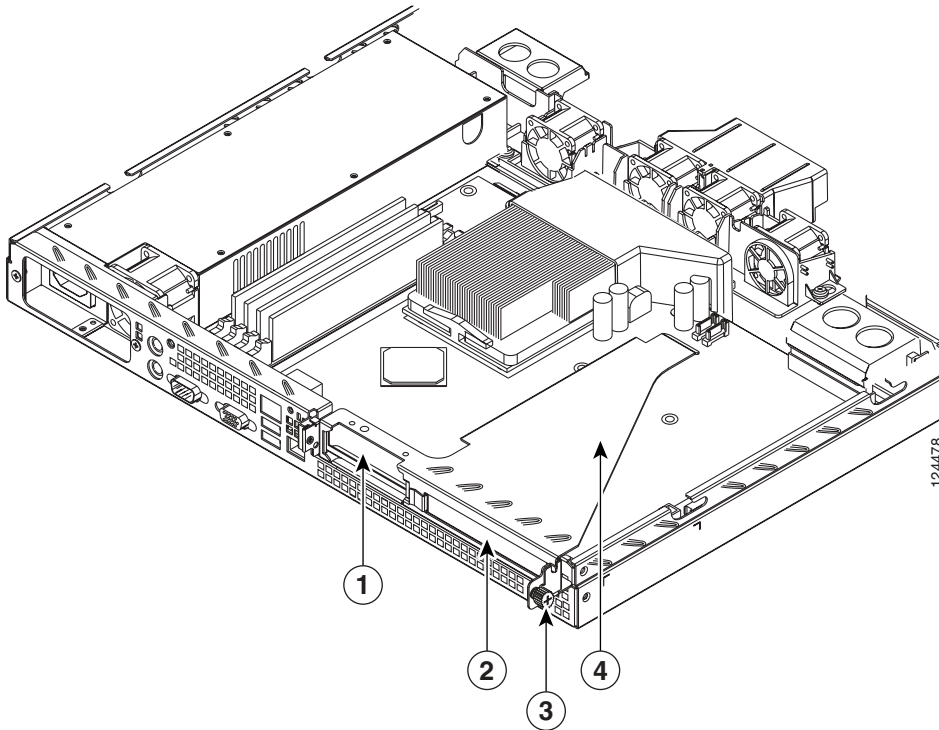

1	Expansion slot cover (slot 2)	2	Expansion slot cover (slot 1)
3	Captive screw	4	Riser card assembly

Step 6 Remove the riser card (labeled 1 in [Figure 4-4](#)) from the system board to access the expansion slot.

Figure 4-4 Installing an Adapter in PCI-X Slot 1

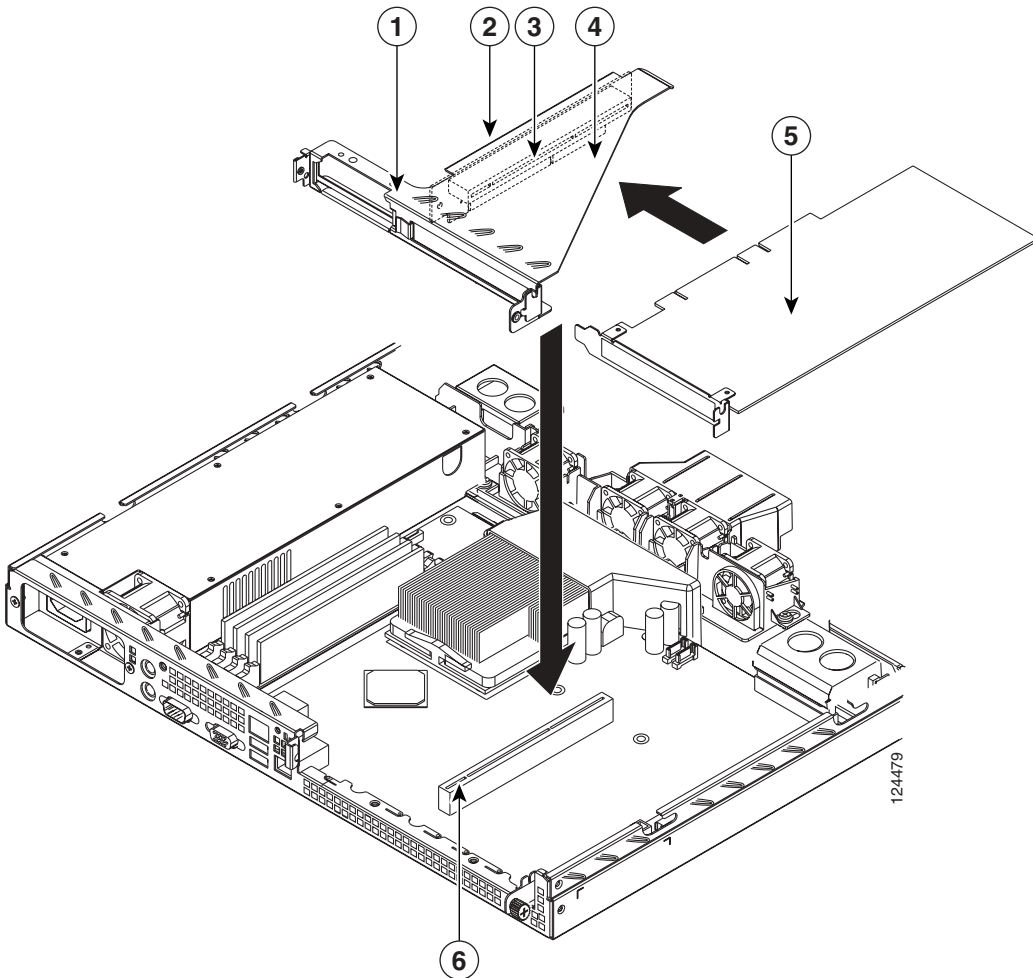

1	Riser card	2	PCI-X slot 2 connector
3	PCI-X slot 1 connector	4	Adapter support bracket
5	Adapter	6	PCI-X riser card connector

- Step 7** Touch the static-protective package containing the adapter to any unpainted metal surface on the Content Engine and then remove the adapter from the static-protective package. Avoid touching the components and gold-plated edge connectors on the adapter.
- Step 8** Place the adapter, component-side up, on a flat, static-protective surface and set any jumpers or switches as described by the adapter manufacturer, if necessary.

**Caution**

When you install an adapter in the Content Engine, be sure that it is completely and correctly seated in the PCI expansion slot before you power up the Content Engine. Incomplete insertion might cause damage to the system board or the adapter.

- Step 9** To install the adapter, carefully grasp the adapter by its top edge or upper corners, align it with the PCI-X slot 1 connector (labeled 2 in [Figure 4-4](#)), and then press the adapter *firmly* into the expansion slot.
- Step 10** Reinstall the riser card. Make sure that the riser card is fully seated in the riser card connector (labeled 5 in [Figure 4-4](#)) on the system board.
- Step 11** Tighten the captive screw for expansion slot 1.
- Step 12** Connect the required cables to the adapter.
- Step 13** If you have other hardware options to install, do so now; otherwise, go to the [“Completing the Installation”](#) section on page 4-16.
-

Preparing and Installing a Fibre Channel Adapter

Fibre Channel is a high-speed data transport technology used for mass storage and networking. Fibre Channel technology is outlined in the SCSI-3 Fibre Channel Protocol (SCSI-FCP).

The Fibre Channel adapter uses a multimode shortwave optical interface for distances up to 1640 feet (500 meters). It is a 2-gigabit (Gb) Fibre Channel device that supports data transfer rates up to 200 megabytes per second (MBps) half duplex and 400 MBps full duplex on optical interfaces.

Preparing to Install the Adapter

Before you begin the installation, do these tasks:

- Read the [“Fiber-Optic Cabling Guidelines for the Fibre Channel Adapter”](#) section.
- Read the [“Tools and Parts Required”](#) section.
- Write down the serial number for future reference.

Fiber-Optic Cabling Guidelines for the Fibre Channel Adapter

To avoid damage to your fiber-optic cables, follow these guidelines:

- Do not route the cable along a folding cable management arm.
- When attaching fiber-optic cables to a Fibre Channel device on slide rails, leave enough slack in the cables so that they do not bend to a radius smaller than 1.5 in. (38 mm) when extended or become pinched when retracted.
- Route the cable away from places where it can snag on other Fibre Channel devices in the rack.
- Do not overtighten the cable straps or bend the cables to a radius smaller than 1.5 in. (38 mm).
- Do not put excess weight on the cable at the connection point and be sure that the cable is well supported.

Tools and Parts Required

To install the Fibre Channel adapter in your system, you need the following items:

- Small Phillips screwdriver
- Logical Cable (LC)-LC Fibre Channel cable (this cable is not provided by Cisco Systems; you must order it separately)

Installing the Fibre Channel Adapter

To install the Fibre Channel adapter, follow these steps:

-
- Step 1** Check the system board and locate the correct PCI-X slot for the Fibre Channel card.
 - Step 2** Power down any connected peripheral devices and then power down the Content Engine.
 - Step 3** Disconnect the power cords.
 - Step 4** Remove the cover. (See the [“Removing the Cover and Bezel”](#) section on [page 4-1.](#))
 - Step 5** Remove the expansion slot cover. (See [Figure 4-3.](#))
 - Step 6** Align the adapter with the slot 2 connector on the riser card. Carefully press the adapter into the expansion slot until it is fully seated and secure. (See [Figure 4-4.](#))
 - Step 7** Reinstall the riser card. Make sure that the riser card is fully seated in the riser card connector on the system board.
 - Step 8** Connect one end of an LC-LC Fibre Channel cable to the optical interface connector on the Fibre Channel adapter card. Connect the other end to a Fibre Channel device.
 - Step 9** Carefully install and secure the cover. (See the [“Completing the Installation”](#) section on [page 4-16.](#))
 - Step 10** Connect the power cables.
 - Step 11** Power on all external Fibre Channel devices; then power on the Content Engine.
 - Step 12** Verify the installation by checking the LEDs. (See [Table 1-6 on page 1-10.](#))
-

Troubleshooting the Fibre Channel Adapter Installation

Three types of adapter installation problems might cause your Fibre Channel adapter to function incorrectly:

- Hardware problems
- System configuration problems
- Fibre Channel problems

Hardware Problems

Take the following actions to determine if your installation problem is caused by the hardware:

1. Verify that all adapters are installed securely.
2. Verify that all cables are attached securely to the correct connectors. Be sure that one end of the LC-LC Fibre Channel cable is attached to the optical interface connector and that the other end is connected to the Fibre Channel device.
3. Verify that the Fibre Channel adapter is installed correctly and is fully seated in the correct expansion slot.
4. Verify that all peripheral devices are turned on.

System Configuration Problems

Verify that the Fibre Channel adapter card is installed in the correct PCI-X slot. If you still have a system configuration problem, contact Cisco technical support for assistance. (See the [“Obtaining Technical Assistance”](#) section on page -xxii.)

Fibre Channel Problems

To determine if your installation problem is caused by an attached Fibre Channel device, perform the following tasks:

1. Verify that all of the Fibre Channel devices were turned on before you turned on the Content Engine.
2. Ensure that all cables are connected properly.
3. Verify that you configured your RAID storage subsystems using the utilities provided by the manufacturer.
4. If your Fibre Channel switch supports zoning, make sure that your peripheral device is configured to the same switch zone as the Fibre Channel adapter.

Working with Hard Disk Drives

This section describes how to install a hard disk drive in the Content Engine. The CE-511 requires a Serial Advanced Technology Attachment (SATA) hard disk drive. CE-566 supports two 1-inch (2.54-cm) slim 3.5-inch (8.89-cm) LVD hard disk drives. The CE-566 requires a SCSI hard disk drive.

Installing a Hard Disk Drive in the CE-511

To install a simple-swap SATA hard disk drive in a bay, complete the following steps.

**Note**

All hard disk drives being used in the Content Engine should have the same throughput speed rating. Mixing hard disk drives with different speed ratings will cause all hard disk drives to operate at the lower throughput speed.

**Note**

If your Content Engine has only one hard disk drive, install it in the left drive bay.

**Caution**

To maintain proper system cooling, do not operate the Content Engine for more than 10 minutes without either a hard disk drive or a filler panel installed in each bay.

- Step 1** Inspect the new drive for any signs of damage.
- Step 2** Review the information in the [“Safety Warnings” section on page 2-1](#), and the [“Safety Guidelines” section on page 2-4](#).
- Step 3** Power down the Content Engine and peripheral devices, and disconnect the power cord and all external cables.
- Step 4** Press the release tabs on the bezel and pull the bezel away from the Content Engine. (See [Figure 4-2](#).)

- Step 5** Install the hard disk drive in the bay.
- Align the drive assembly (see [Figure 4-5](#)) with the guide rails in the bay.
 - Gently push the drive assembly into the drive bay until the drive connects to the backplane.
 - Check the hard disk drive status LED to verify that the hard disk drive is operating properly.

If the amber hard disk drive status LED for a drive is lit continuously, that individual drive is faulty and needs to be replaced. If the green hard disk drive activity LED is flashing, the drive is being accessed.

Figure 4-5 Installing a SATA Hard Disk on CE-511

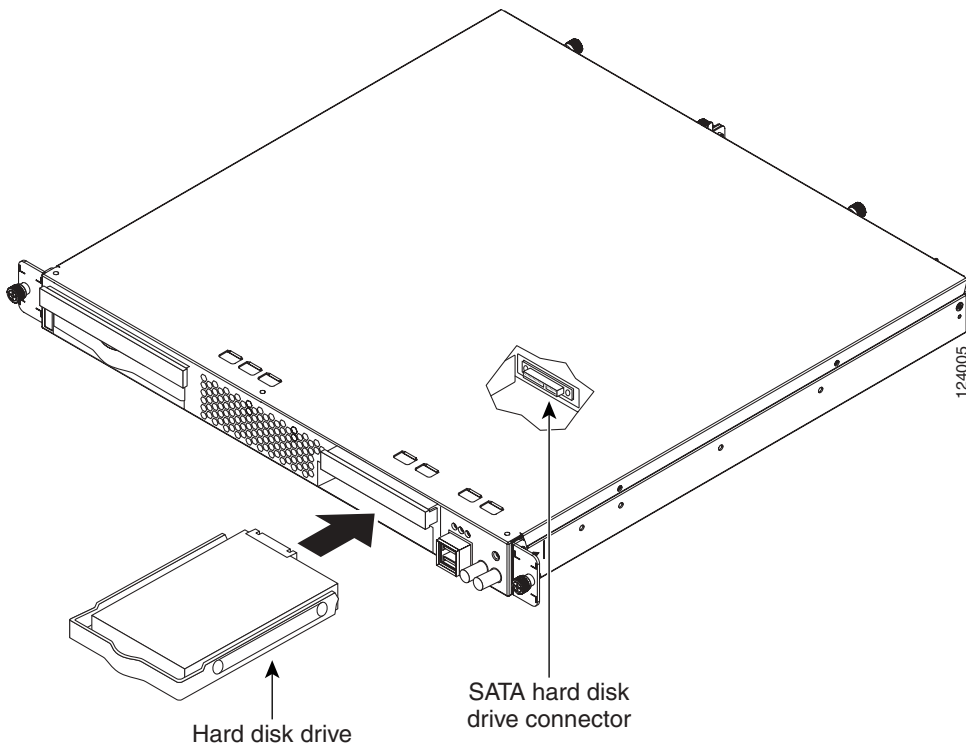

Installing a Hard Disk Drive in the CE-566

To install a SCSI hard disk drive in CE-566, complete the following steps.

**Note**

All hard disk drives being used in the Content Engine should have the same throughput speed rating. Mixing hard disk drives with different speed ratings will cause all hard disk drives to operate at the lower throughput speed.

**Note**

If your Content Engine has only one hard disk drive, install it in the left drive bay.

**Note**

To maintain proper system cooling, do not operate the Content Engine for more than 10 minutes without either a hard disk drive or a filler panel installed in each bay.

- Step 1** Inspect the new drive for any signs of damage.
- Step 2** Review the information in the [“Safety Warnings”](#) section on page 2-1, and the [“Safety Guidelines”](#) section on page 2-4.
- Step 3** Power down the Content Engine and peripheral devices, and disconnect the power cord and all external cables.
- Step 4** Press the release tabs on the bezel and pull the bezel away from the Content Engine. (See [Figure 4-2](#).)
- Step 5** Slide the drive tray out of the Content Engine.
- Step 6** Position the hard disk drive on the tray. (See [Figure 4-6](#).)
- Step 7** Secure the hard disk drive using screws.
- Step 8** Slide the tray back into the Content Engine.
- Step 9** Connect the power and signal cables to the drive.
- Step 10** Replace the bezel.

Figure 4-6 Installing a SCSI Hard Disk on CE-566

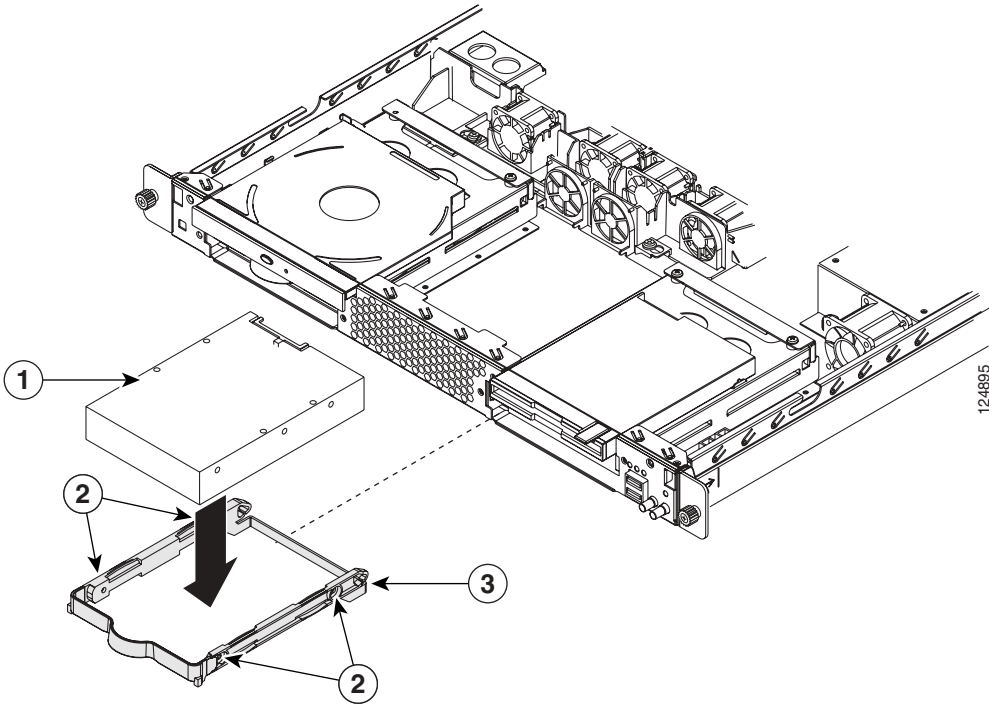

1	SCSI hard disk drive	2	Screws
3	Hard disk drive tray		

Assigning SCSI IDs

When you replace a SCSI disk drive in a CE-566, you must assign SCSI IDs 0 and 1 to the disk drives. The SCSI IDs are assigned by placing or removing jumpers on the disk drive SCSI ID pins.

**Note**

The disk drives have a label on the lower side that identifies the pins. You can locate the pins corresponding to SCSI ID bit 0 by referring to this label.

Assign SCSI ID 0 to the disk drive in drive bay 2 (located below the flash memory card on right hand side of your Content Engine) by removing any jumpers from the SCSI ID pins. (Other jumpers should be set the same as the jumper settings on the drive that is being replaced.)

Assign SCSI ID 1 to the disk drive in drive bay 1 (located below the CD-ROM drive) by placing a jumper on the pins corresponding to SCSI ID bit 0.

To check whether the configuration is correct, refer to the boot time messages on the device console. For example:

```
Attached scsi disk sda at scsi0, channel 0, id 0, lun 0
Attached scsi disk sdb at scsi0, channel 0, id 1, lun 0
```

Completing the Installation

To complete your installation, reinstall the bezel, reinstall the Content Engine cover, and reconnect all cables that you disconnected earlier. Follow the instructions in this section.

**Caution**

To maintain proper cooling and airflow, install the Content Engine cover before turning on the Content Engine. Operating the Content Engine for extended periods (over 30 minutes) with the Content Engine cover removed might damage Content Engine components.

Installing the Content Engine Cover and Bezel

Complete the following steps to install the Content Engine cover and bezel:

-
- Step 1** Install the cover by placing it into position and sliding it forward. Then tighten the captive screws (labeled 1 in [Figure 4-7](#)).



Caution Before sliding the cover forward, make sure that the cover will properly engage the ledge at the front of the Content Engine.

- Step 2** Install the bezel.
- Align the hooks on the bottom of the bezel with the Content Engine.
 - Press the bezel toward the Content Engine until it clicks into place.

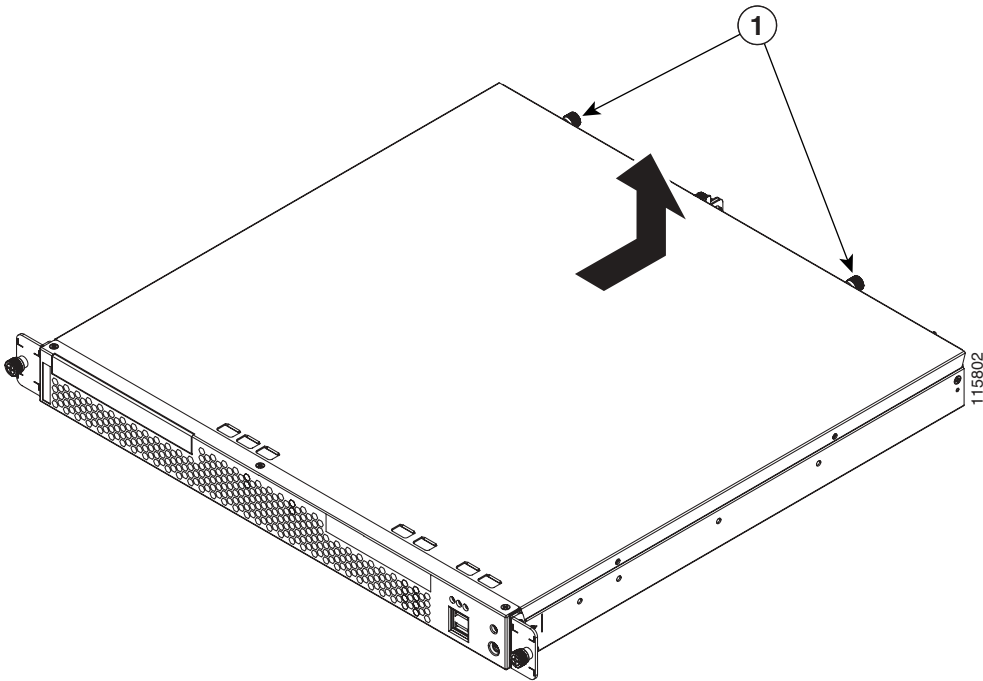
Figure 4-7 *Installing the Content Engine Cover*

- Step 3** Install the Content Engine in the rack. See the [“Installing a CE-511 or CE-566 Unit” section on page 3-2](#) for instructions.
- Step 4** Connect all external cables and the power cord to the Content Engine, and then plug the power cord into a properly grounded electrical outlet.
-



Troubleshooting the System Hardware

If your system is not working as expected, begin troubleshooting using the procedures in this chapter. This chapter guides you through some initial checks and procedures that can solve basic system problems.

This chapter contains the following sections:

- [Checking the Basics, page 5-1](#)
- [Checking Connections and Switches, page 5-2](#)

Checking the Basics

The following procedure leads you through the checks necessary to solve some basic system problems:

-
- Step 1** Was an alert message issued by the system software?
- Yes.* Check the component named in the alert message.
- No.* Go to [Step 2](#).
- Step 2** Visually inspect the chassis. Is the system wet or damaged?
- Yes.* Liquid spills, splashes, and excessive humidity can cause damage to the system. If an external device such as an external drive gets wet, contact your service representative for instructions. (See the [“Obtaining Technical Assistance” section on page xxii.](#))

If the chassis was dropped or damaged while being moved, you should check the system to see if it functions properly. If an external device attached to the system is dropped or damaged, contact your service representative for instructions. (See the [“Obtaining Technical Assistance”](#) section on page xxii.)

No. Go to [Step 3](#).

Step 3 Perform the steps in the [“Checking Connections and Switches”](#) section on page 5-2.

Is the problem resolved?

Yes. The power to the system was faulty, or the connections to the system were loose. You have fixed the problem.

No. Go to [Step 4](#).

Step 4 Verify the settings in the system setup program. For details, see the software configuration guide that shipped with your system.

Did the system complete the boot routine?

Yes. The system configuration information was incorrect. You have fixed the problem.

No. Call your service representative. (See the [“Obtaining Technical Assistance”](#) section on page xxii.)

Checking Connections and Switches

Improperly set switches and controls and loose or improperly connected cables are the most likely source of problems for the chassis or other external equipment. A quick check of all the switches, controls, and cable connections can easily solve these problems. (See [Figure 1-5](#) and [Figure 1-6](#) for the location of front panel controls and indicators. See [Figure 1-9](#) for the location of back panel connections on the system.)

To check all the connections and switches, perform the following steps:

-
- Step 1** Power down the system, including any attached peripherals such as external drives. Disconnect all the power cables from their electrical outlets.
- Step 2** If the system is connected to a power strip (or power distribution unit), turn the power strip off and then on again.
- Is the power strip receiving power?
- Yes.* Go to [Step 5](#).
- No.* Go to [Step 3](#).
- Step 3** Plug the power strip into another electrical outlet.
- Is the power strip receiving power?
- Yes.* The original electrical outlet probably does not function. Use a different electrical outlet.
- No.* Go to [Step 4](#).
- Step 4** Plug a system that you know works into the electrical outlet.
- Does the system receive power?
- Yes.* The power strip is probably not functioning properly. Use another power strip.
- No.* Go to [Step 5](#).
- Step 5** Reconnect the system to the electrical outlet or power strip.
- Make sure that all connections fit tightly together.
- Step 6** Power up the system.
- Is the problem resolved?
- Yes.* The connections were loose. You have fixed the problem.
- No.* Call your service representative. (See the [“Obtaining Technical Assistance” section on page xxii.](#))
-



Maintaining the Content Engine

Proper use of preventive maintenance procedures can keep the Content Engine in top operating condition and minimize the need for costly, time-consuming service procedures. This chapter contains maintenance procedures that you should perform regularly.

This chapter covers the tasks required for maintaining a Content Engine or a Content Engine farm:

- [Maintaining Your Site Environment, page 6-1](#)
- [Using Power Protection Devices, page 6-7](#)

Maintaining Your Site Environment

An exhaust fan in the power supply cools the power supply and system by drawing air in through various openings in the system and blowing it out the back. However, the fan also draws dust and other particles into the system, causing contaminant buildup, which results in an increase in the system's internal temperature and interferes with the operation of various system components.

To avoid these conditions, we recommend keeping your work environment clean to reduce the amount of dust and dirt around the system, thereby reducing the amount of contaminants drawn into the system by the power supply fan.

This section discusses various environmental factors that can adversely affect system performance and longevity.

Temperature

Temperature extremes can cause a variety of problems, including premature aging and failure of chips or mechanical failure of devices. Extreme temperature fluctuations can cause chips to become loose in their sockets and can cause expansion and contraction of disk drive platters, resulting in read or write data errors.

To minimize the negative effects of temperature on system performance, follow these guidelines:

- Ensure that the system is operated in an environment no colder than 50°F (10°C) or hotter than 95°F (35°C).
- Ensure that the system has adequate ventilation. Do not place it within a closed-in wall unit or on top of cloth, which can act as insulation. Do not place it where it will receive direct sunlight, particularly in the afternoon. Do not place it next to a heat source of any kind, including heating vents during winter.

Adequate ventilation is particularly important at high altitudes. System performance may not be optimum when the system is operating at high temperatures as well as high altitudes.

- Make sure that all slots and openings on the system remain unobstructed, especially the fan vent on the back of the system.
- Clean the system at regular intervals to avoid any buildup of dust and debris, which can cause a system to overheat.
- If the system has been exposed to abnormally cold temperatures, allow a 2-hour warm-up period to bring it up to normal operating temperature before turning it on. Failure to do so may cause damage to internal components, particularly the hard disk drive.
- If intermittent system failures are noticed, try reseating any socketed chips, which might have become loose because of temperature fluctuations.

Humidity

High-humidity conditions can cause moisture migration and penetration into the system. This moisture can cause corrosion of internal components and degradation of properties such as electrical resistance, thermal conductivity, physical strength, and size. Extreme moisture buildup inside the system can result in electrical shorts, which can cause serious damage to the system.

Each system is rated to operate at 8 to 80 percent relative humidity, with a humidity gradation of 10 percent per hour. Buildings in which climate is controlled by air conditioning in the warmer months and by heat during the colder months usually maintain an acceptable level of humidity for system equipment. However, if a system is located in an unusually humid location, a dehumidifier can be used to maintain the humidity within an acceptable range.

Altitude

Operating a system at high altitude (low pressure) reduces the efficiency of forced and convection cooling and can result in electrical problems related to arcing and corona effects. This condition can also cause sealed components with internal pressure, such as electrolytic capacitors, to fail or perform at reduced efficiency.

Each system is rated to operate at a maximum altitude of 6998 feet (2133 meters) and can be stored at a maximum altitude of 15,000 feet (4570 meters).

Dust and Particles

A clean operating environment can greatly reduce the negative effects of dust and other particles, which act as insulators and interfere with the operation of a system's mechanical components. Also, in addition to regular cleaning, you should follow these guidelines to deter contamination of the system equipment:

- Do not permit smoking anywhere near the system.
- Do not permit food or drink near the system.
- Use dust covers when the system is not in use.
- Close windows and outside doors to keep out airborne particles.

Corrosion

The oil from a person's fingers or prolonged exposure to high temperature or humidity can corrode the gold-plated edge connectors and pin connectors on various devices in the system. This corrosion on system connectors is a gradual process that can eventually lead to intermittent failures of electrical circuits.

To prevent corrosion, you should avoid touching contacts on boards and cards. Protecting the system from corrosive elements is especially important in moist and salty environments, which tend to promote corrosion. Also, as a further deterrent to corrosion, the system should not be used in extreme temperatures, as explained in the [“Temperature” section on page 6-2](#).

Electrostatic Discharge

Electrostatic discharge (ESD) results from the buildup of static electricity on the human body and certain other objects. This static electricity is often produced by simple movements such as walking across a carpet. ESD is a discharge of a static electrical charge that occurs when a person whose body contains such a charge touches a component in the system. This static discharge can cause components, especially chips, to fail. ESD is a problem particularly in dry environments where the relative humidity is below 50 percent.

To reduce the effects of ESD, you should observe the following guidelines:

- Wear a grounding wrist strap. If a grounding wrist strap is unavailable, touch an unpainted metal surface on the chassis periodically to neutralize any static charge.
- Keep components in their antistatic packaging until they are installed.
- Avoid wearing clothing made of wool or synthetic materials.

Electromagnetic and Radio Frequency Interference

Electromagnetic interference (EMI) and radio frequency interference (RFI) from a system can adversely affect devices such as radio and television (TV) receivers operating near the system. Radio frequencies emanating from a system can also interfere with cordless and low-power telephones. Conversely, RFI from high-power telephones can cause spurious characters to appear on the system's monitor screen.

RFI is defined as any EMI with a frequency above 10 kilohertz (kHz). This type of interference can travel from the system to other devices through the power cable and power source or through the air like transmitted radio waves. The Federal Communications Commission (FCC) publishes specific regulations to limit the amount of EMI and RFI emitted by computing equipment. Each system meets these FCC regulations.

To reduce the possibility of EMI and RFI, follow these guidelines:

- Operate the system only with the system cover installed.
- Ensure that the screws on all peripheral cable connectors are securely fastened to their corresponding connectors on the back of the system.
- Always use shielded cables with metal connector shells for attaching peripherals to the system.

Magnetism

Because they store data magnetically, hard disk drives are extremely susceptible to the effects of magnetism. Hard disk drives should never be stored near magnetic sources such as the following:

- Monitors
- TV sets
- Printers
- Telephones with real bells
- Fluorescent lights

Power Source Interruptions

Systems are especially sensitive to variations in voltage supplied by the AC power source. Overvoltage, undervoltage, and transients (or spikes) can erase data from memory or even cause components to fail. To protect against these types of problems, power cables should always be properly grounded and one or both of the following methods should be used:

- Use one of the power protection devices described in the [“Using Power Protection Devices” section on page 6-7](#).
- Place the system on a dedicated power circuit (rather than sharing a circuit with other heavy electrical equipment). In general, do not allow the system to share a circuit with any of the following:
 - Copier machines
 - Air conditioners
 - Vacuum cleaners
 - Space heaters
 - Power tools
 - Teletype machines
 - Adding machines
 - Laser printers
 - Facsimile machines
 - Any other motorized equipment

Besides these appliances, the greatest threats to a system’s supply of power are surges or blackouts caused by electrical storms. Whenever possible, turn off the system and any peripherals and unplug them from their power sources during thunderstorms.

If a blackout occurs—even a temporary one—while the system is turned on, turn off the system immediately and disconnect it from the electrical outlet. Leaving the system on may cause problems when the power is restored; all other appliances left on in the area can create large voltage spikes that can damage the system.

Using Power Protection Devices

A number of devices are available that protect against power problems such as power surges, transients, and power failures. The following subsections describe some of these devices.

Surge Protectors

Surge protectors are available in a variety of types and usually provide a level of protection commensurate with the cost of the device. Surge protectors prevent voltage spikes, such as those caused during an electrical storm, from entering a system through the electrical outlet. Surge protectors, however, do not offer protection against brownouts, which occur when the voltage drops more than 20 percent below the normal AC line voltage level.

Line Conditioners

Line conditioners go beyond the overvoltage protection of surge protectors. Line conditioners keep a system's AC power source voltage at a fairly constant level and therefore can handle brownouts. Because of this added protection, line conditioners cost more than surge protectors—up to several hundred dollars. However, these devices cannot protect against a complete loss of power.

Uninterruptible Power Supplies

Uninterruptible power supply (UPS) systems offer the most complete protection against variations in power because they use battery power to keep the system running when AC power is lost. The battery is charged by the AC power while it is available, so once AC power is lost, the battery can provide power to the system for a limited amount of time—from 15 minutes to an hour or so—depending on the UPS system.

UPS systems range in price from a few hundred dollars to several thousand dollars, with the more expensive units allowing you to run larger systems for a longer period of time when AC power is lost. UPS systems that provide only 5 minutes of battery power let you conduct an orderly shutdown of the system, but are not intended to provide continued operation. Surge protectors should be used with all UPS systems, and the UPS system should be Underwriters Laboratories (UL) safety-approved.



A

- A/V ports
 - description [1-12](#)
- AC power
 - receptacle [1-12](#)
- AC power cords
 - connecting [3-13](#)
- adapters
 - description [1-17](#)
 - installing [4-5](#)
- altitude
 - guidelines [6-3](#)
 - specifications [1-20](#)

B

- back panel
 - LEDs (figure) [1-9](#)
 - LEDs (table) [1-9](#)
 - ports (table) [1-12](#)
- bays
 - description [1-17](#)

C

- cables
 - connecting [3-12](#)
- cabling requirements
 - Ethernet standard (note) [1-13](#)
- caching
 - web traffic [1-5](#)
- cautions
 - description of [xii](#)
- CD eject button
 - description [1-7](#)
- CD-ROM drive LED
 - description [1-8](#)
- Class A warnings [1-22](#)
- connections
 - cables [3-12](#)
 - power [3-13](#)
 - troubleshooting [5-2](#)
- connectors and ports
 - description [1-11 to 1-15](#)
- console
 - connecting to port [3-12](#)
- Content Delivery Network
 - description [1-5](#)

Content Engine

- back panel [1-11](#)
 - Class A warnings [1-22](#)
 - front panel [1-7](#)
 - functional description [1-4](#)
 - installing [3-2](#)
 - installing in a 2-post rack [3-3, 3-4](#)
 - maintaining [6-1](#)
 - regulatory compliance [1-20](#)
 - removing or replacing [3-14](#)
- control buttons
- front panel [1-7](#)
- conventions
- document [xi](#)
- corrosion
- preventing damage [6-4](#)
- covers
- installing [4-17](#)
 - removing [4-1](#)

D

dimensions

- Content Engine [1-19](#)
- disk drives. *See* hard disk drives
- document
- conventions [xi](#)
- dust
- preventing damage [6-3](#)

E

- electrical input
- specifications [1-19](#)
- electromagnetic interference
- See EMI
- electrostatic discharge
- See ESD
- EMI
- preventing effects of [6-5](#)
- environment
- maintaining [6-1](#)
- ESD
- preventing damage [2-6, 6-4](#)
- Ethernet 1 activity LED [1-9](#)
- Ethernet 1 link LED [1-9](#)
- Ethernet 1 port [1-12](#)
- Ethernet 2 activity LED [1-9](#)
- Ethernet 2 link LED [1-9](#)
- Ethernet 2 port [1-12](#)
- Ethernet connections [3-12](#)
- Ethernet controller [1-2, 1-13](#)
- Ethernet ports
- cabling requirements (note) [1-13](#)
 - connector pinout [1-13](#)
 - description [1-13](#)
- expansion bays
- description [1-17](#)
- expansion slots

description [1-17](#)

F

Fibre Channel adapter

connector [1-15](#)

LEDs (table) [1-10](#)

port

description [1-12](#)

specifications (table) [1-18](#)

front panel

control buttons (table) [1-7](#)

figure [1-7](#)

LEDs (figure) [1-8](#)

LEDs (table) [1-8](#)

functional description

Content Engine [1-4](#)

H

hard disk controller

description [1-17](#)

hard disk drive LED

description [1-8](#)

hard disk drives

assigning SCSI IDs [4-16](#)

installing [4-12](#)

SCSI [4-12](#)

serial ATA [4-12](#)

specifications

for CE-511 [1-4](#)

for CE-566 [1-4](#)

hardware

troubleshooting [5-1](#)

heat dissipation

specifications [1-20](#)

humidity

maintenance guidelines [6-3](#)

specifications [1-20](#)

I

I/O connectors [1-11](#)

installation

rack [3-6](#)

tabletop [3-11](#)

warnings [2-1](#)

installing

adapters [4-5](#)

covers [4-17](#)

hard disk drives [4-12](#)

L

LEDs

back panel (figure) [1-9](#)

back panel (table) [1-9](#)

checking [3-14](#)

front panel (figure) [1-8](#)

front panel (table) [1-8](#)

line conditioners

using [6-7](#)

local-area network

Ethernet [1-2](#)

M

magnetism

preventing effects of [6-5](#)

maintenance [6-1 to 6-6](#)

memory specifications

for CE-511 [1-4](#)

for CE-566 [1-4](#)

microprocessor

description [1-17](#)

MPEG A/V decoder adapter

connectors [1-12, 1-15](#)

installing [4-5](#)

N

network

removing Content Engine from [3-14](#)

noise emissions

specifications [1-20](#)

P

PCI-X slots [4-4](#)

pinouts, MPEG A/V decoder audio and video connectors [1-16](#)

ports

and connectors

description [1-11 to 1-15](#)

back panel (table) [1-12](#)

Ethernet

connecting [3-12](#)

serial

connecting [3-12](#)

power

connecting to system [3-13](#)

power control button

description [1-7](#)

power control button shield [3-14](#)

power LED

description [1-8](#)

power receptacles

description [1-12](#)

power requirement [1-19](#)

power source interruptions

preventing damage from [6-6](#)

power supplies

receptacles [1-12](#)

specifications [1-18](#)

using uninterruptible [6-7](#)

R

- rack installation [3-6](#)
- rack-mount brackets
 - figure [3-3](#)
- rack-mount kit
 - contents of [3-5](#)
- radio frequency interference. *See* RFI
- receptacles
 - power [1-12](#)
- regulatory compliance [1-20](#)
- removing or replacing
 - Content Engine [3-14](#)
- reset button
 - description [1-7](#)
- RFI
 - preventing effects of [6-5](#)

S

- safety
 - general precautions [2-4](#)
- safety warnings [2-1](#)
- SATA [4-12](#)
- SCSI cable
 - attaching [3-12](#)
- SCSI hard disk drives (note) [4-12](#)
- SCSI IDs
 - assigning bit numbers [4-16](#)

- SCSI LVD ports
 - connector pinout [1-14](#)
 - description [1-14](#)
 - for Storage Array [1-12](#)
- serial ATA hard disk drive [4-12](#)
- serial ports
 - connector pinout [1-14](#)
 - description [1-12, 1-13](#)
- shield
 - power control button [3-14](#)
- site environment
 - maintenance factors [6-1](#)
- slots
 - specifications [1-17](#)
- specifications
 - Content Engine (table) [1-17](#)
- Storage Array
 - connecting to [3-12](#)
- surge protectors
 - using [6-7](#)
- switches
 - troubleshooting [5-2](#)
- system error LED
 - description [1-8](#)

T

- tabletop installation
 - procedure [3-11](#)

temperature
 maintenance guidelines [6-2](#)
 specifications [1-20](#)

tools
 for rack-mounting [3-2](#)

troubleshooting
 basic checks [5-1](#)
 connections [5-2](#)
 switches [5-2](#)
 system hardware [5-1](#)

Web Cache Communication Protocol. *See*
 WCCP

web traffic
 caching [1-5](#)

weight
 Content Engine [1-19](#)

U

uninterruptible power supplies
 using [6-7](#)

V

video ports
 connectors [1-15](#)
 connectors (figure) [1-16](#)
 description [1-12](#)

W

warnings
 Class A [1-22](#)
 installation [2-1](#)

WCCP [1-5](#)